

DETAIL 1

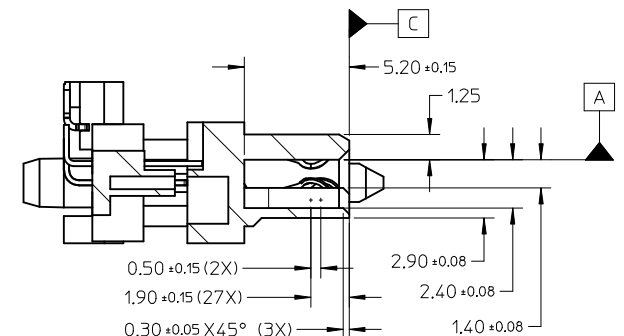
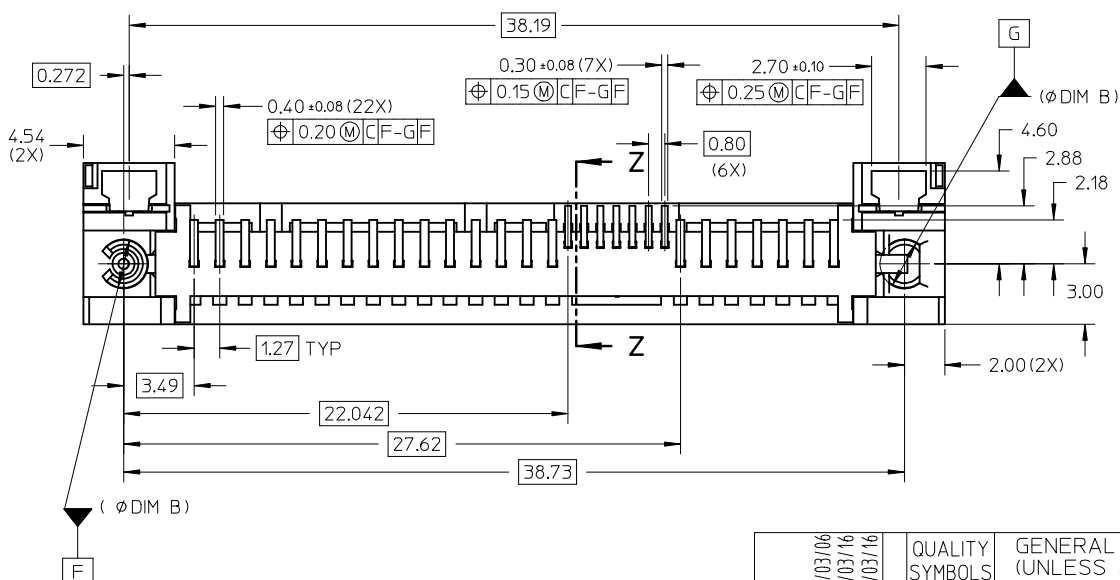

SECTION Z-Z

SEE SHT 1 EC NO: S2017-0457 DRWN:SKANG 2017/03/06 CHKD:MLONG 2017/03/16 APPR:MLONG 2017/03/16	QUALITY SYMBOLS	GENERAL TOLERANCES (UNLESS SPECIFIED)		DIMENSION STYLE	SCALE	DESIGN UNITS	THIRD ANGLE PROJECTION
	$\nabla_A = 0$	mm	INCH	MM ONLY	NTS	METRIC	
	$\nabla_C = 0$	4 PLACES ± --- ± ---	BOKOK 2008/02/01	DRAWN BY	DATE	TITLE	SAS RECEPTACLE EXTENDED HEIGHT, SMT WITH SOLDER TAB MOLEX INCORPORATED
	$\nabla_B = 0$	3 PLACES ± --- ± ---	YKOH 2008/02/18	CHECKED BY	DATE		
	2 PLACES ± 0.20 ± ---	BOKOK 2010/02/19	APPROVED BY	DATE			
	1 PLACE ± --- ± ---		MATERIAL NO.	DOCUMENT NO.			
	ANGULAR ± 3°	DRAFT WHERE APPLICABLE MUST REMAIN WITHIN DIMENSIONS		SEE TABLE			
		SIZE	THIS DRAWING CONTAINS INFORMATION THAT IS PROPRIETARY TO MOLEX INCORPORATED AND SHOULD NOT BE USED WITHOUT WRITTEN PERMISSION				

10 9 8 7 6 5 4 3 2 1

F

E

D

C

B

A

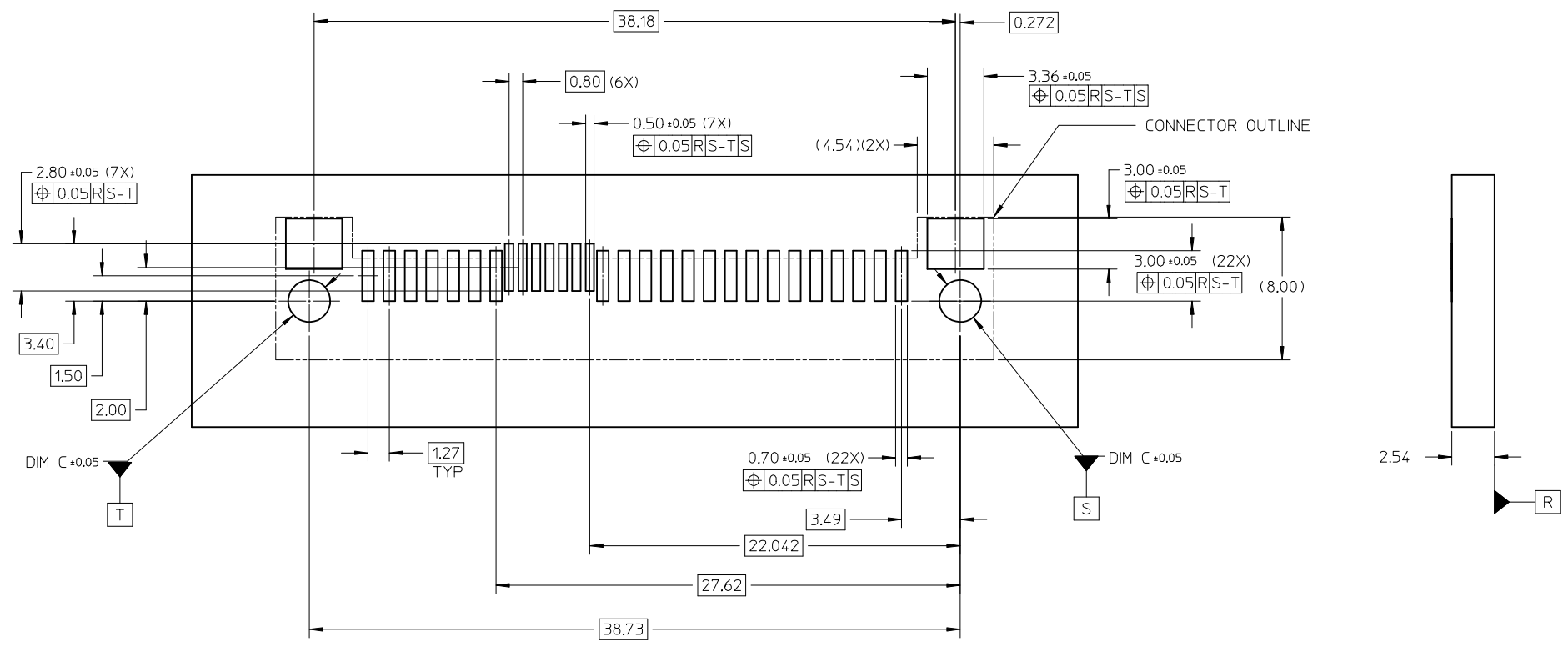

RECOMMENDED PCB LAYOUT

SEE SHT 1 EC NO: S2017-0457 DRWN:SKANG 2017/03/06 CHKD:MLONG 2017/03/16 APPR:MLONG 2017/03/16	QUALITY SYMBOLS	GENERAL TOLERANCES (UNLESS SPECIFIED)		DIMENSION STYLE	SCALE	DESIGN UNITS	THIRD ANGLE PROJECTION
	$F_A=0$	mm	INCH	MM ONLY	NTS	METRIC	
	$F_C=0$	4 PLACES ± ---	± ---	DRAWN BY	DATE	TITLE	
	$F_P=0$	3 PLACES ± ---	± ---	BOKOK	2008/02/01	SAS RECEPTACLE EXTENDED HEIGHT, SMT WITH SOLDER TAB	
	2 PLACES ± 0.20	± ---	CHECKED BY	DATE	MOLEX INCORPORATED		
	1 PLACE ± ---	± ---	YKOH	2008/02/18	MATERIAL NO.		SHEET NO.
	ANGULAR ± 3 °		APPROVED BY	DATE	DOCUMENT NO.		
	DRAFT WHERE APPLICABLE MUST REMAIN WITHIN DIMENSIONS		BOKOK	2010/02/19	SD-78367-001		3 OF 5
			SEE TABLE	THIS DRAWING CONTAINS INFORMATION THAT IS PROPRIETARY TO MOLEX INCORPORATED AND SHOULD NOT BE USED WITHOUT WRITTEN PERMISSION			

9 8 7 6 5 4 3 2 1

TRAY PACKAGING

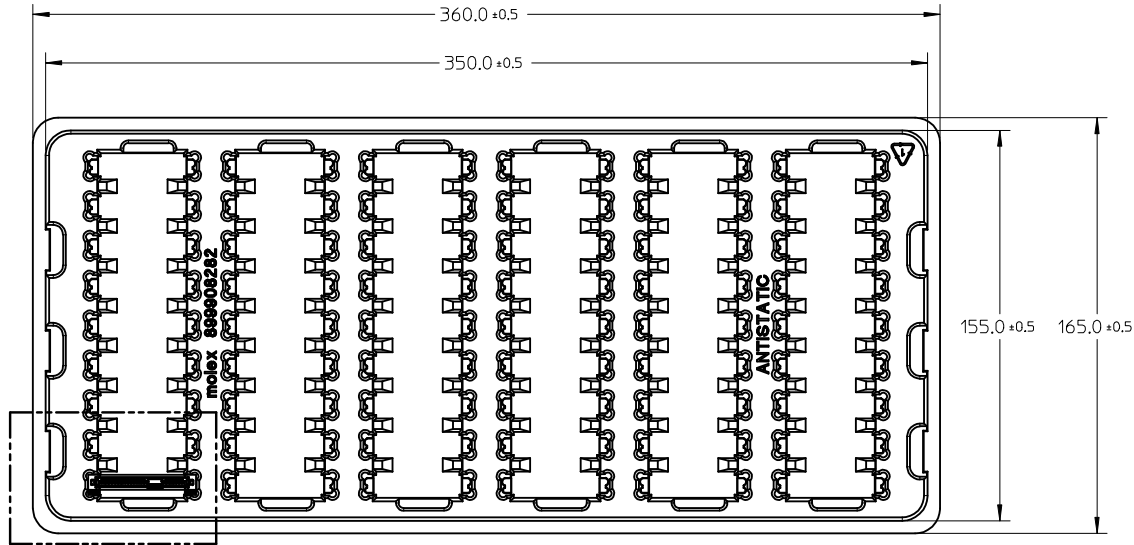

- NOTES:
 1. PACKAGING QTY: 54PCS/TRAY
 2. NO PICK AND PLACE CAP

DETAIL 2

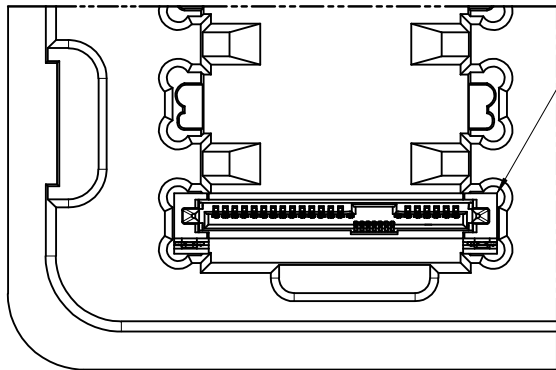

PART ORIENTATION IN TRAY

DETAIL 2

SEE SHT 1 EC NO: S2017-0457 DRWN:SKANG 2017/03/06 CHKD:MLONG 2017/03/16 APPR:MLONG 2017/03/16	QUALITY SYMBOLS F _A =0 F _C =0 F _P =0	GENERAL TOLERANCES (UNLESS SPECIFIED)		DIMENSION STYLE	SCALE	DESIGN UNITS	THIRD ANGLE PROJECTION
		mm	INCH	MM ONLY	NTS	METRIC	
B	DESCRIPTION	4 PLACES	± ---	± ---	DRAWN BY	DATE	TITLE
		3 PLACES	± ---	± ---	BOKOK	2008/02/01	SAS RECEPTACLE EXTENDED HEIGHT, SMT WITH SOLDERTAB
		2 PLACES	± 0.20	± ---	CHECKED BY	DATE	
		1 PLACE	± ---	± ---	YKOH	2008/02/18	
ANGULAR ± 3 °		APPROVED BY		DATE	MOLEX INCORPORATED		
DRAFT WHERE APPLICABLE MUST REMAIN WITHIN DIMENSIONS		SEE TABLE		MATERIAL NO.	DOCUMENT NO.		SHEET NO.
				SIZE	THIS DRAWING CONTAINS INFORMATION THAT IS PROPRIETARY TO MOLEX INCORPORATED AND SHOULD NOT BE USED WITHOUT WRITTEN PERMISSION		

TAPE AND REEL PACKAGING

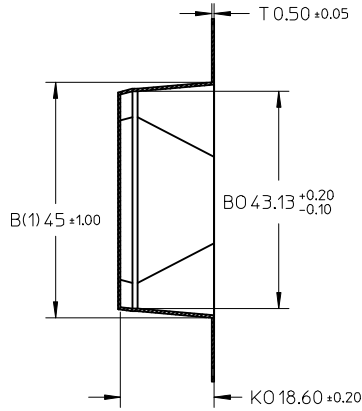

SECTION Y-Y

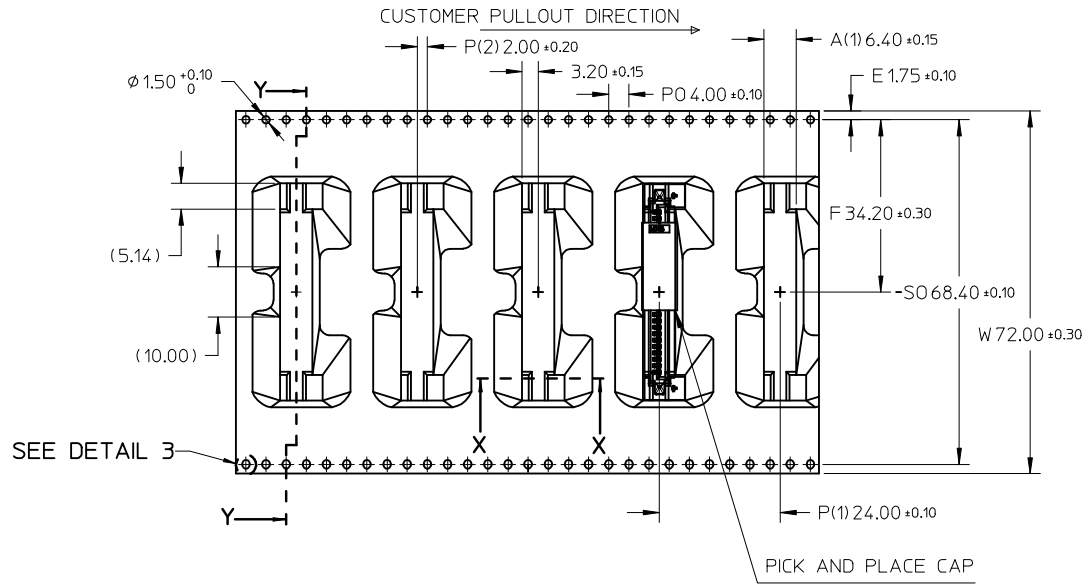

NOTES:

1. LEADER AND TRAILER TAPE

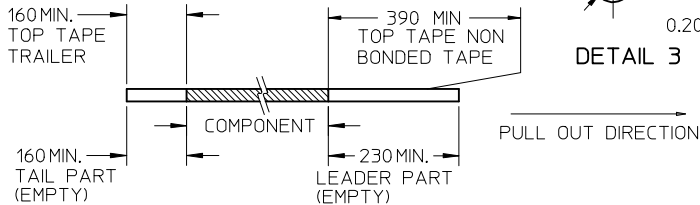

DETAIL 3

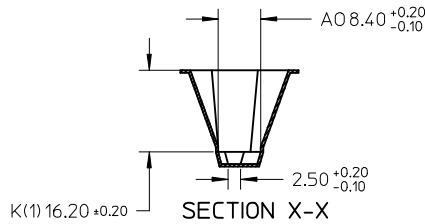

SECTION X-X

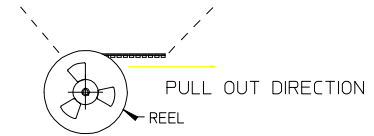

2. PEELING OFF FORCE OF THE TOP TAPE: 20 - 80gf.
(PEELING DIRECTION AS SHOWN IN FOLLOWING FIGURE)

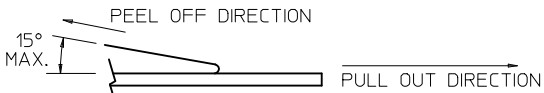

- 3. TAPE AND REEL SPECIFICATION IS AS PER EIA-481.
- 4. TAPE AND REEL QUANTITY : 100 PCS/ REEL.
- 5. THE TAPE IS TREATED FOR ANTI-STATIC.
- 6. COLOUR: BLACK. THICKNESS: 0.50mm THICK.

SEE SHT 1 EC NO: S2017-0457 DRWN:SKANG 2017/03/06 CHKD:MLONG 2017/03/16 APPR:MLONG 2017/03/16	QUALITY SYMBOLS $\nabla_A = 0$ $\nabla_C = 0$ $\nabla_P = 0$	GENERAL TOLERANCES (UNLESS SPECIFIED)		DIMENSION STYLE	SCALE	DESIGN UNITS	THIRD ANGLE PROJECTION	
				MM ONLY	NTS	METRIC		
			mm	INCH	DRAWN BY	DATE	TITLE	
		4 PLACES	± ---	± ---	BOKOK	2008/02/01	SAS RECEPTACLE EXTENDED HEIGHT, SMT WITH SOLDER TAB	
3 PLACES	± ---	± ---	CHECKED BY	DATE				
2 PLACES	± 0.20	± ---	YKOH	2008/02/18				
1 PLACE	± ---	± ---	APPROVED BY	DATE				
ANGULAR ± 3 °			BOKOK	2010/02/19				
DRAFT WHERE APPLICABLE MUST REMAIN WITHIN DIMENSIONS		SEE TABLE		MATERIAL NO.	DOCUMENT NO.	SHEET NO.		
		SIZE A3		THIS DRAWING CONTAINS INFORMATION THAT IS PROPRIETARY TO MOLEX INCORPORATED AND SHOULD NOT BE USED WITHOUT WRITTEN PERMISSION		SD-78367-001 5 OF 5		