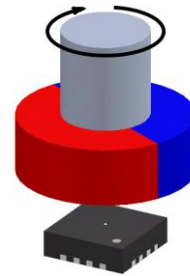


Key Features

- UVW Signals for Block Commutation**
- 11-Bit Resolution Absolute Angle Encoder**
- 500kHz Refresh Rate**
- Ultra-Low Latency: 3 μs**
- Serial Interface for Data Readout and Settings**
- 10-Bit Incremental Output (A, B, Z)**
- Built-In Linearization for Side-Shaft Mounting**
- 7.5mA Supply Current**



QFN-16 3x3mm Package

General Description

The MagAlpha MA300 is a magnetic sensor designed to replace the 3 Hall switch solutions for 3-phase block commutation in brushless dc motors. The IC detects the absolute angular position of a permanent magnet, typically a diametrically magnetized cylinder attached to the rotor. The MagAlpha is an extremely fast acquisition and processing sensor, allowing accurate angle measurement at speeds from 0 to 120'000 RPM.

Since the measurement is spatially confined, the user has flexibility in terms of magnet shapes and configurations. This helps relax mechanical tolerances and, in case the end-of-shaft position is not available, the MagAlpha MA300 operates away from the axis of rotation (“side-shaft” mounting).

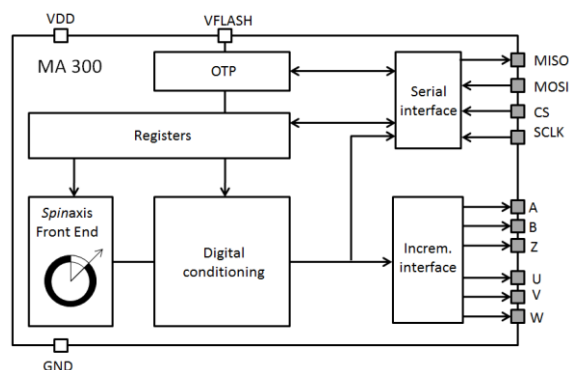


Figure 1: Functional Block Diagram

1. Specifications

TABLE 1. OPERATING CONDITIONS

Parameters	Symbol	Min	Typ	Max	Unit
Supply Voltage	VDD	3.0	3.3	3.6	V
Supply Current	I _{sup}	5.7	6.6	8.0	mA
Supply Voltage for OTP Flashing	V _{flash}	3.6		3.8	V
Supply Current for OTP Flashing ⁽¹⁾	I _{flash}	50		100	mA
Operating Temperature					°C
Thermal Resistor Sensor/Environment	T _{op}	-40	40	125	K/V
Applied Magnetic Field	B	30	75	150	mT

(1) See section 11 for more details about the supply circuit for OTP flashing.

TABLE 2. SENSOR OUTPUT SPECIFICATIONS

Measurement conditions: VDD = 3.3V, 50mT < B < 100mT, Temp = -40...+125°C, unless otherwise noted

Parameters	Min	Typ	Max	Unit	Remark
Power-Up Time		2	3	ms	
INL	+/- 0.7	+/- 1.5	+/-2.5	deg	
Output Drift					
Temperature Induced	+/-0.005	+/-0.008	+/-0.05	deg/°C	
Magnetic Field Induced	-0.005	-0.01	-0.025	deg/mT	
Voltage Supply Induced	0.0007	0.001	0.005	deg/mV	
Absolute Output - Serial					
Data Output Length	16		16	bit	
Refresh Rate	500	520	550	kHz	
Latency	2	3	4	µs	
Resolution (3σ Noise Level)	10.5	11.0	11.5	bit	
Incremental Output					
Resolution	256		1024	edge/revol.	
Jitter		10		% of a period	
Hysteresis			0.35	deg	
Digital I/O					
Threshold Voltage High		1.75		V	
Threshold Voltage Low		1.05		V	
Rising Edge Slew Rate		0.7		V/ns	CL = 50 pF
Falling Edge Slew Rate		0.7		V/ns	CL = 50 pF
Maximum Sink/Source Current per Pin		4		mA	

2. Timing of the Serial Interface

The data link is a 4-wire serial bus, complying to the Serial Peripheral Interface (SPI) usual convention (see Table 3 and Table 4). The MagAlpha sensor operates as slave. During one transmission, a 16-bit word can be sent simultaneously to the sensor MOSI and received from the sensor MISO (see Figure 2). Note that it is possible to receive 24 bits of data (16 bits for the angle and 8 bits for a time index). For additional details, refer to the “Output Signals” section.

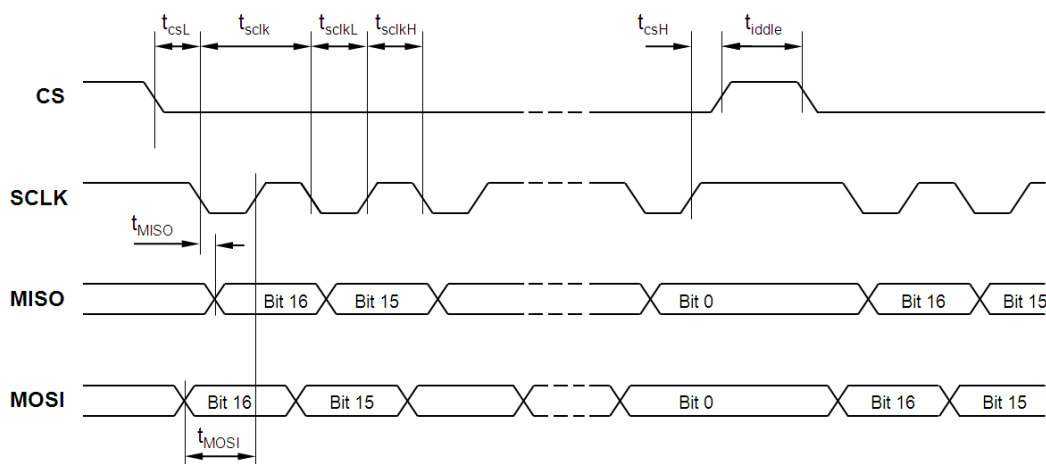


Figure 2: SPI Timing Diagram

TABLE 3. SPI SPECIFICATION

SCLK Idle State	High
SCLK Readout Edge	Rising
CS Idle State	High
Data Order	MSB First

TABLE 4. SPI STANDARD

CPOL	1
CPHA	1
MODE	3
DORD	0

TABLE 5. SPI TIMING

Parameter	Description	Min	Max	Unit
t_{idle}	Time between two subsequent transmissions.	20		ns
t_{csL}	Time between CS falling edge and SCLK falling edge.	25		ns
t_{sklk}	SCLK period.	40		ns
t_{sklkL}	Low level of SCLK signal.	20		ns
t_{sklkH}	High level of SCLK signal.	20		ns
t_{csH}	Time between SCLK rising edge and CS rising edge.	25		ns
t_{MOSI}	Data input valid to SCLK reading edge.	15		ns
t_{MISO}	SCLK setting edge to data output valid.		15	ns

3. Registers

TABLE 6. REGISTER MAP

Register Address											
No	Hex	Bin	Bit 7 MSB	Bit 6	Bit 5	Bit 4	Bit 3	Bit 2	Bit 1	Bit 0 LSB	
3	0x3	0011	BCT(7:0)								
4	0x4	0100	Z(11:4)								
5	0x5	0101	0	0	ETY	ETX	Z(3:0)				
9	0x9	1001	F7	-	F5	F4	F3	-	-	-	

TABLE 7. PROGRAMMING PARAMETERS

Parameters	Symbol	Number of Bits	Brief Description	See Table
Bias Current Trimming	BCT	8	For side-shaft configuration, reduce the Hall device bias current of the X- and/or Y-axis.	9
Zero Setting	Z	12	Sets the zero position.	11
Enable Trimming X	ETX	1	When enabled, the X-axis bias current is trimmed by the quantity BCT.	10
Enable Trimming Y	ETY	1	When enabled, the Y-axis bias current is trimmed by the quantity BCT.	10
Flash Register <i>n</i>	F<i>n</i>	1	Flashes the content of register number <i>n</i> .	

4. Pin Configuration

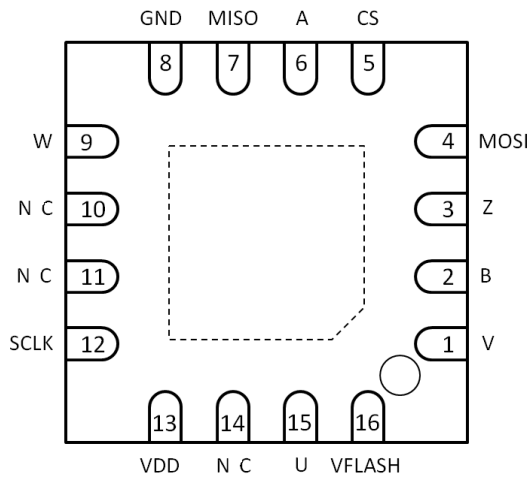


Figure 3: QFN-16 Top View

TABLE 8. PIN FUNCTIONS

No	Name	Function
1	V	V (Incremental Output)
2	B	B (Incremental Output)
3	Z	Z (Incremental Output)
4	MOSI	Data In (Serial)
5	CS	Chip Select (Serial)
6	A	A (Incremental Output)
7	MISO	Data Out (Serial)
8	GND	Ground
9	W	W (Incremental Output)
10	NC	-
11	NC	-
12	SCLK	Clock (Serial)
13	VDD	3.3V Supply
14	NC	-
15	U	U (Incremental Output)
16	VFLASH	3.6V Supply for OTP Flashing

5. Sensor – Magnet Mounting

The sensitive volume of the MA300 is confined in a region less than 100µm wide and has multiple, integrated Hall devices. This volume is located both horizontally and vertically (with a precision 50µm in the center of the QFN package). The sensor detects the angle of the magnetic field projected in a plane parallel to the upper surface of the package, making the only magnetic field that matters, the *in-plane* component (X and Y components) in the middle point of the package.

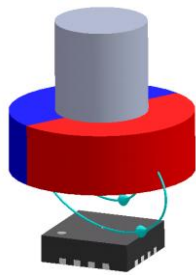


Figure 4: End-of-Shaft Mounting

This detection mode allows flexibility for the design of an angular encoder. All the sensor needs is the magnetic vector to lie essentially within the sensor plane with its amplitude between 30mT and 150mT. Note that the MA300 works with fields smaller than 30mT, but the linearity and resolution performance may deviate from the

specifications (see Table 2). The straightforward solution places the MA300 sensor on the rotation axis of a permanent magnet, i.e., a cylinder diametrically magnetized (see Figure 4).

If the end-of-shaft position is not available, the sensor can be positioned away from the rotation axis of a cylinder or ring magnet (see Figure 5). In this case, the magnetic field angle is no longer directly proportional to the mechanical angle. The MA300 can be adjusted to compensate this effect and recover the linear relation between the mechanical angle and the sensor output. With multiple pole pairs, the MA300 indicates multiple rotations for each mechanical turn.

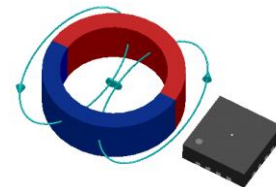


Figure 5: Side-Shaft Mounting

6. Power Supply Decoupling

For most applications, a single 100nF bypass capacitor placed close to the supply pins sufficiently decouples the MA300 from noise from the power supply. If improved decoupling is required, a larger capacitor (10 µF) can be added in parallel with the 100nF capacitor, and/or a resistor (10Ω) can be added between the supply line and the capacitor node.

In any case, make sure that the connection between the MA300 ground and the power supply ground has low impedance in order to avoid noise transmitted from the ground.

VFLASH must be supplied only when flashing the memory. Otherwise VFLASH can remain unconnected or grounded (see Figure 6).

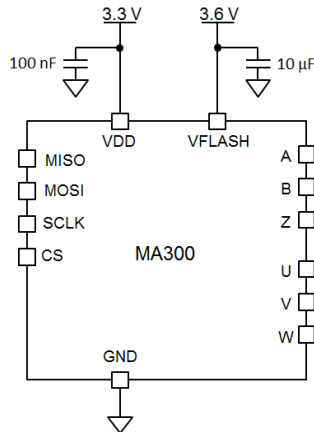


Figure 6: Connection for Supply Decoupling

7. Sensor Front-End

The magnetic field is detected with integrated Hall devices located in the center of the package. The particularity of this sensor is that the angle is measured using the *spinaxis* method, which digitizes directly the direction of the field without any ATAN computation or a feedback loop based circuit (interpolators, etc.).

The *spinaxis* method is based on *phase detection*. It requires a sensitive circuitry generating a sinusoidal signal with a *phase* that represents the angle of the magnetic field. The angle is then retrieved by a time-to-digital converter, which counts the time between the zero crossing of the sinusoidal signal and the edge of a constant waveform (see Figure 7). The digitized time is the front-end output.

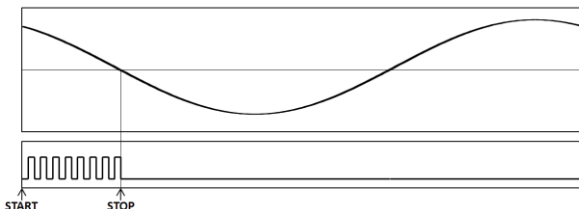


Figure 7: Phase Detection Method. Top: Sine Waveform.
Bottom: Clock of Time-to-Digital Converter.

Looking further down the treatment chain, it is crucial that the signal treatment does not add unwanted phase shifts. For this purpose, the MagAlpha incorporates an architecture that automatically compensates these shifts, resulting in the stability displayed in Table 2. In short, the front-end delivers in a straightforward and open-loop manner a digital number proportional to the angle of the magnetic field at the rate of 500kHz.

Side-Shaft

The default current biasing of the Hall devices is adjusted by programming to accommodate a low field or compensate non-linearities inherent to side-shaft configurations (see Figure 8).

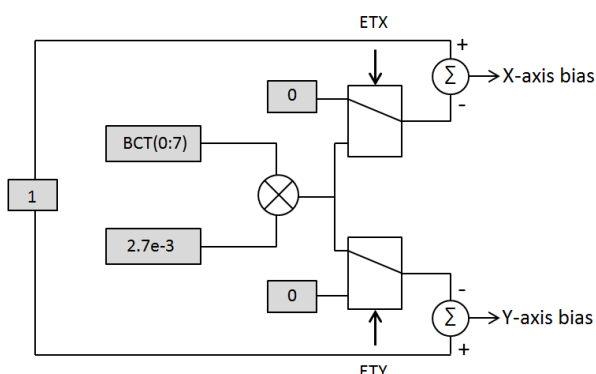


Figure 8: Hall Devices Biasing Diagram

If the MA300 is mounted in a side-shaft configuration, the relationship between the field angle and the mechanical angle is no longer directly linear. This effect is related in that the tangential magnetic field is usually smaller than the radial field. We define the field ratio k in equation (1):

$$k = B_{rad}/B_{tan} \quad (1)$$

where B_{rad} and B_{tan} are the maximum radial, respectively, tangential magnetic field (see Figure 9).

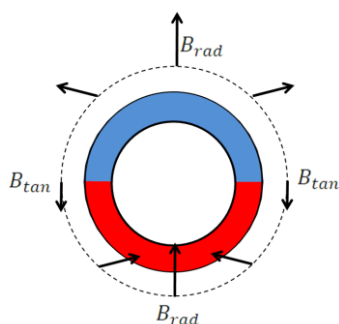


Figure 9: Side-Shaft Field

255 (see Table 9). For optimum compensation, the radial axis should be reduced by the quantity in equation (2):

$$BCT(7:0) = \frac{255}{0.667} \left(1 - \frac{1}{k}\right) \quad (2)$$

TABLE 9. EXAMPLE OF OPTIMUM BCT SETTING

BCT(7:0)	Magnet Ratio k
0	1
1	1.003
...	...
128	1.50
...	...
255	3.00

The dot printed on the package informs whether the radial field is detected by sensor X or Y components (see Figure 10).

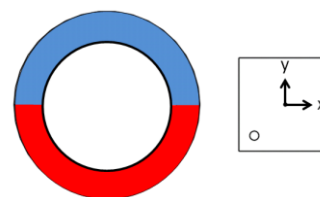


Figure 10: Package Top View with X and Y Axes

First the user must determine which axis must be reduced (see the qualitative field distribution around a ring in Figure 9). For instance, with the arrangement depicted in Figure 8, the X-axis should be reduced. Then the parameter ETX or ETY can be set. Note that if both ETX and ETY are set to 1, the current bias will be reduced in both directions the same way, i.e. without side-

8. Digital Signal Conditioning

The ratio k depends on the magnet geometry and the distance to the sensor.

The X-axis or Y-axis bias currents can be reduced to recover an equal Hall signal for all angles and therefore suppress the non-linearity. The current reduction is set by the parameter bias current trimming, BCT (7:0), which is an integer from 0 to

shaft correction (see Table 10).

TABLE 10. ETX AND ETY

ETX	Enable Trimming the X-Axis
0	Disabled
1	Enabled
ETY	Enable Trimming the Y-Axis

Digital Filtering

Advanced digital filtering improves the resolution without adding latency. The principle is to measure the rotation *speed* over the last 512 data points (in addition to the angular position) to evaluate of the present position with the best possible accuracy. This principle gives a lag-free position at constant speed.

Zero Setting

The zero position of the MagAlpha (α_0), can be programmed with 12-bit resolution. The angle streamed out (α_{out}) is given by equation (3):

$$\alpha_{out} = \alpha_{fe} - \alpha_0 \quad (3)$$

Where α_{fe} is the raw angle out of the front-end. The parameter Z(11:0), which is 0 by default, determines α_0 (see Table 18). This setting is valid for all output formats: SPI, ABZ, and UV.

0	Disabled
1	Enabled

9. Programming the MA300

The MA300 incorporates 3 programmable registers. Each register has an 8 bit of memory. When the MA300 is powered up, each of these 3x8 bits are set to zero, unless the register was previously stored in the one-time programmable (OTP) memory. This means that during start-up, the content of the OTP memory is copied to the registers. Once flashed, the register content can no longer be modified.

In order to set the content of a register, the user must send a digital stream composed of the 4-bit REGISTER WRITE command (0010), followed by

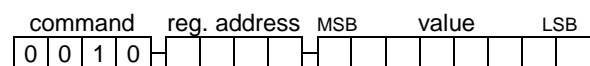
TABLE 11. ZERO POSITION

Z(11:0)	Zero Position α_0 (deg)
0	0
1	0.088
...	...
4095	359.912

Rotation Direction

Looking at the MagAlpha top, the angle increases when the magnetic field rotates clockwise.

a 4-bit register address and the 8-bit value to be sent to the register. The data stream, sent through the MOSI wire, is therefore 16-bits long:

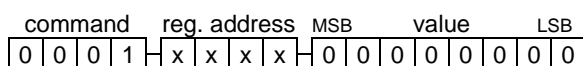


Once the command is sent, it is immediately effective and affects the next data sent from the MagAlpha.

Read Back the Register Content

It might be helpful to check the content of a register, for instance to verify that the programming was successful. The user must send

the REGISTER READ command (0001), then the 4-bit address of the register being tested. The last 8 bits of the stream will be ignored. The user can send for instance 0000 0000:

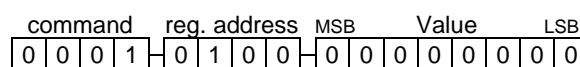


The MagAlpha response is *within the same transmission*. In the first byte (simultaneous to the 4-bit READ command and the 4-bit address), the

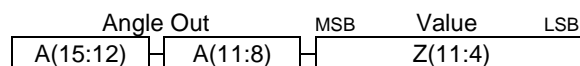
MagAlpha sends the 8 MSB of the measured angle A(15:8). The second byte is the content of the register being tested. After this transmission, the MagAlpha continues delivering the usual 16-bit angles A(15:0).

Example

To check the content of register 4 (0100), which contains 8 MSB's of the zero setting, send the data:



Simultaneously the MagAlpha replies:



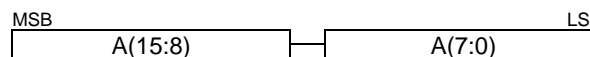
10. Output Signals

The bit order of the transmitted data is MSB first, LSB last. The timing requirements are indicated in section 3. Every 2µs, new data is transferred into the output buffer. The master device connected to the MagAlpha triggers the reading by pulling CS down. When a falling edge of the CS signal occurs, the data remains in the output buffer until the CS signal returns to logic 1. When the CS is low, the master can read the data by sending clock pulses with a maximum frequency of 25MHz. There is no minimum frequency or timeout. See Figure 11 for a simple reading of 16-bit data.

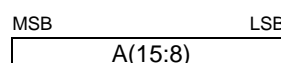


Figure 11: Timing Diagram for Simple SPI Readout

A full reading requires 16 clock pulses. The MA300 delivers:



If the user needs less resolution (since the MSB is sent first), they can read the angle by sending less than 16 pulses. For instance, by sending only 8 pulses, the MagAlpha provides an 8-bit angle without ambiguity over 360 deg:



If the master triggers the reading faster than the refresh rate, the MagAlpha may send the same data point several times.

In some applications, it is helpful to know how many data updates occur between two successive readouts or if the same data points were read more than once. For this purpose, the user can read an 8-bit index attached to the data. This keeps track of the precise time of measurement without the need of precisely controlling the readout time. This index runs from 0 to 255 and is incremented by 1 each time the output buffer is

refreshed. Using the index, the user can detect a double reading of the same data (same index), or the user can see how many data points were skipped (see Figure 12).

For reading the 8-bit index, the master has to send $16 + 8 = 24$ clock pulses.

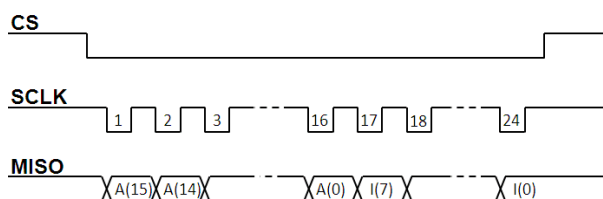


Figure 12: Timing Diagram for SPI Angle + Index Readout

Incremental - ABZ

With the ABZ output, the MA300 emulates a 10-bit incremental encoder, such as an optical encoder, providing logic pulses in quadrature (see Figure 13). Compared to signal signal B is shifted by a quarter of the pulse period. Over one revolution, signal A pulses 256 times; it makes 256-1024 edges per revolution. Signal Z (“Zero” or “Index”) raises only once per turn, at the zero angle position.

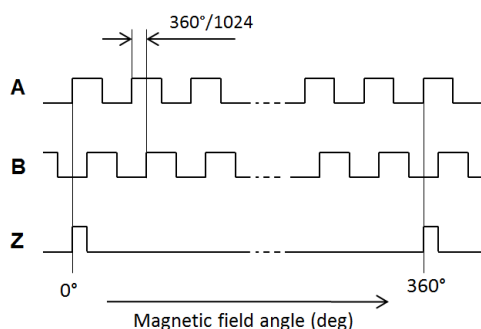


Figure 13 : ABZ Output during Rotation

Block Commutation - UVW

The UVW output emulates the three Hall switches usually used for the block commutation of the 3-phase electric motor. The three logic signals have

a duty cycle of $\frac{1}{2}$ and are shifted 60 deg relative to each other (see Figure 14).

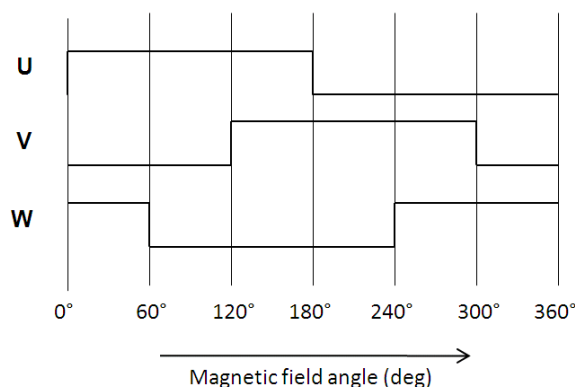


Figure 14. UVW Output during Rotation

11. OTP Programming

The one-time programmable (OTP) memory permanently stores the content of the programmable registers. The OTP memory is made of poly-silicon fuses. By activating the “flash” command, the content of the entire register is stored in the OTP memory. The flash command consists in setting some bits (F_n , where n is the register number) in register 9. When the bit F_n is set, the register n is stored permanently. **Important: the user can flash only one register at a time.** It is possible to operate the MagAlpha without flashing the registers (see Fig. 15).

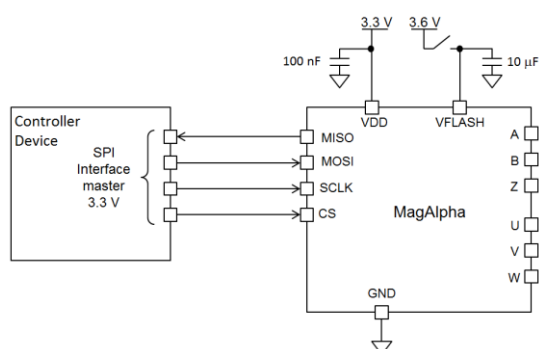


Figure 15. Circuit for Flashing

The burning of the fuses during the flash process is irreversible: Once a register is flashed, the default values at power up will always be the same. After flashing, the registers' content can no longer be modified.

Flashing Procedure

Prior to flashing, it is recommended to test the MagAlpha with the new settings and verify the performance of the sensor.

Once satisfied, the user can proceed with the flashing.

Flashing:

1. Send the parameter to the register, and read back for verification.

2. Tie VFLASH to 3.6V. **Note: It is possible to supply both VDD and VFLASH with the same 3.6V source.**
3. In register 9, set the bit so it corresponds to the register being flashed.
4. Untie VFLASH. Then switch off and on and check by reading back the register content.

Example: Set & flash the zero position at 50 deg

Note: Permanently storing the zero position requires burning two registers (4 and 5).

Permanently Storing the Zero Position:

1. Convert into binary (within a resolution of 12 bits). 50 deg is the binary number, 001000111000 (≈ 49.92 deg).
2. Store the 8 MSB (00100011) of the zero position in register 4:

command	reg. address	MSB	value	LSB
0 0 1 0	0 1 0 0	0 0 1 0	0 0 0 1 1	

3. Read back register 4:

command	reg. address	MSB	value	LSB
0 0 0 1	0 1 0 0	0 0 0 0	0 0 0 0 0 0	

If the programming was correct, the MagAlpha replies with the register 4 content:

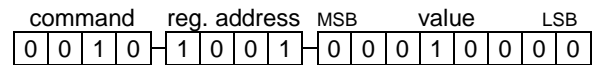
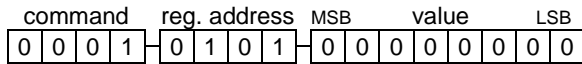
Angle out	MSB	value	LSB
A(15:12)	A(11:8)	0 0 1 0	0 0 0 1 1

4. Store the 4 LSB (1000) of the zero position into the 4 LSB of register 5:

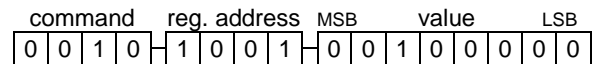
command	reg. address	MSB	value	LSB
0 0 1 0	0 1 0 1	0 0 0 0	0 1 0 0 0	

Angular Sensor for 3-Phase Brushless Motor Commutation and Position Control with Side-Shaft Positioning Capability

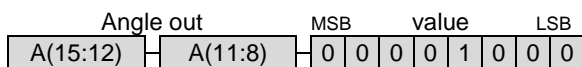
5. Read back register 5:



3. Flash register 5:



The MagAlpha returns:



4. Disconnect VFLASH from 3.6V.

5. Turn the MagAlpha off and on and read back registers 4 and 5 to verify that the flashing was successfully accomplished (steps 3 & 5 in the “Permanently Storing the Zero Position” section).

Complete Flashing:

1. Connect VFLASH to 3.6V.
2. Flash register 4:

12. Typical Characteristics

Measurement conditions: VDD = 3.3V, Temp = 25°C, unless otherwise noted.

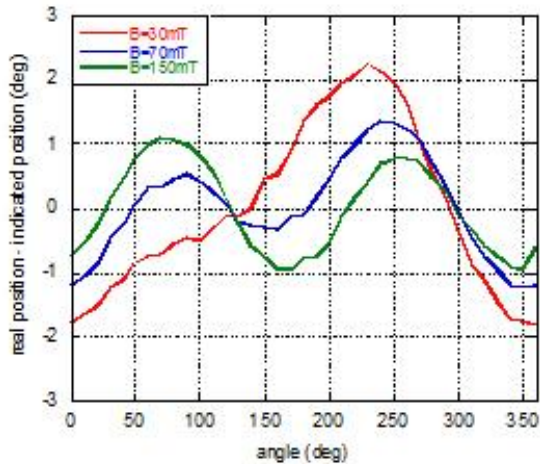


Figure 16: Error Curve at Different Magnetic Fields. The INL is the Maximum Value of this Curve

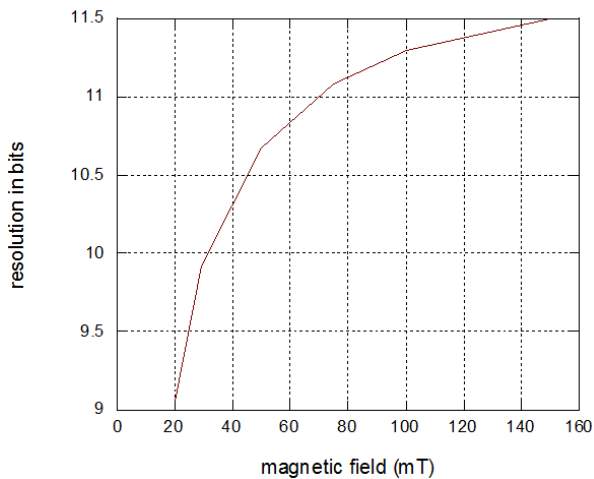
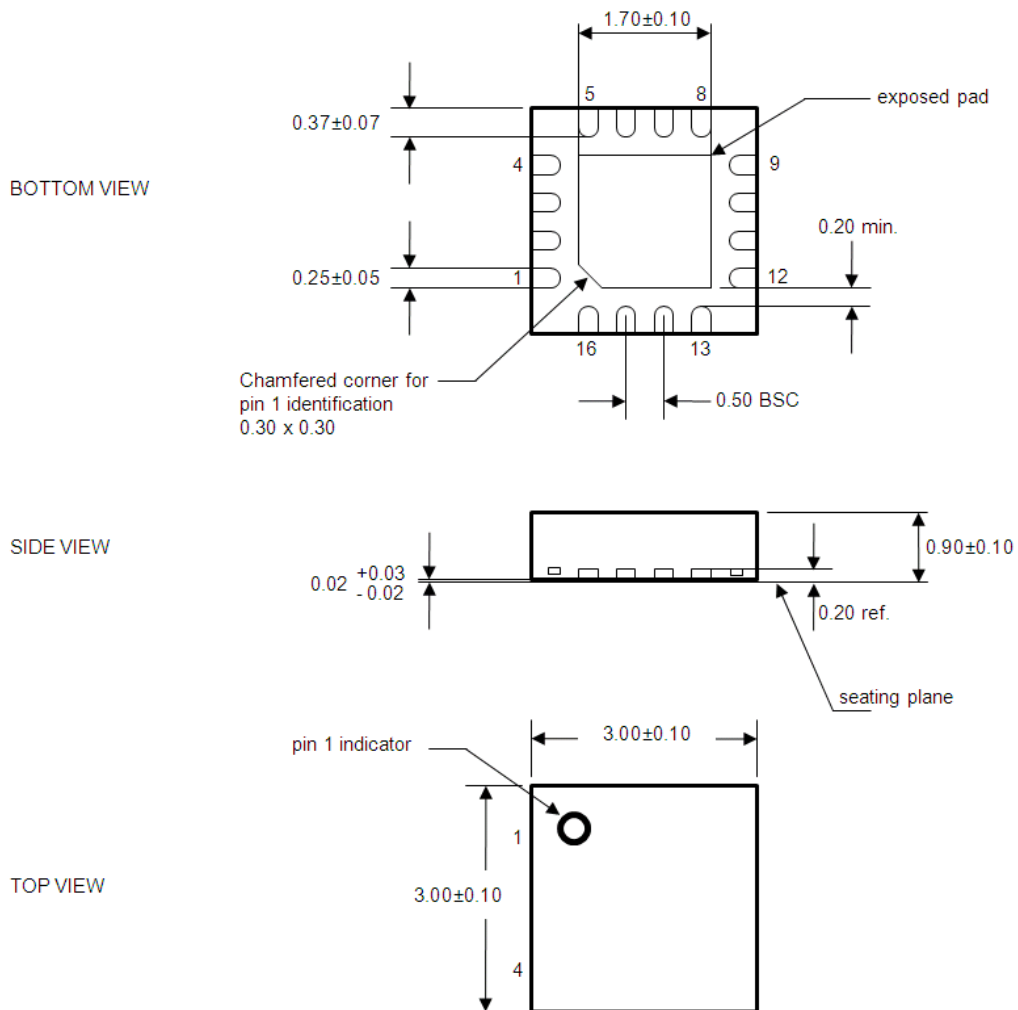


Figure 17: Resolution in Bits (3-Sigma) vs. Magnetic Field

13. Package Dimensions

Package: Plastic Quad Flatpack No-lead QFN-16 3x3mm



NOTES:

1. All dimensions are in mm.
2. Package dimensions do not include mold flash, protrusions, burrs, or metal smearing.
3. Coplanarity shall be 0.08.
4. Compliant with JEDEC MO-220.

14. Ordering Information

Part Number	Package	Free Air Temperature (T _A)
MA300GQ	QFN 3mmx3mm	-40° to 125°

* For Tape & Reel, add suffix -Z (e.g. MA300GQ-Z).

Appendix A: Definitions

- Resolution (3 σ Noise Level)** The smallest angle increment distinguishable from the noise. Here the resolution is defined as 3 times σ , the standard deviation in degrees, taken over 1000 data points at a constant position. The resolution in bits is obtained with: $\log_2(360/6\sigma)$.
- Refresh rate** Rate at which new data points are stored in the output buffer.
- Latency** The time between when the data is ready at the output, and the instant at which the shaft passes that position. The lag in degrees is $lag = latency \cdot v$, where v is the angular velocity in deg/s.
- Power-Up Time** Starting at power-up, the time until the sensor delivers valid data.
- Integral Non-Linearity (INL)** Maximum deviation between the sensor output and the best line fit (see Figure A1).

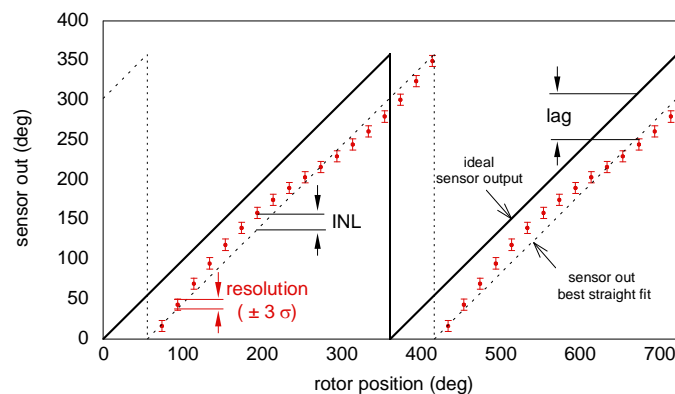


Figure A1: Absolute Angle Errors

- Jitter** For the incremental output maximum fluctuation of the angular position of the raising edges.
- Overall Reproducibility** Maximum variation between two readings, successive or not, of the same shaft position at a fixed magnetic field over the complete temperature range.

Monolithic Power Systems, Inc.
Switzerland
www.sensimatech.com
euroinfo@monolithicpower.com

☎ +41 22 364 63 50

The information provided by Monolithic Power Systems, Inc. in this document is believed to be correct. However MPS reserves the right, without further notice, (i) to change the product specification and/or the information in this document and (ii) to improve reliability, functions, and design of the product and (iii) to discontinue or limit production or distribution of any product version.

Monolithic Power Systems, Inc. does not assume any liability arising out of any application or use of any product or information, including without limitation consequential or incidental damages. All operating parameters must be validated for each customer's application by customer's technical experts. Recommended parameters can and do vary in different applications.

Devices sold by MPS are covered by patents and patent applications. By this publication MPS does not assume responsibility for patent infringements or other rights of third parties which may result from its use.