

LOC G	DIST 36	P	F	REVISIONS		
		LTR		DESCRIPTION	DATE	APPROVED
		E		REV PER 0G3A-0637-01	030CT02	JR/MS

- ① CLEANED, UNPLATED
- ② PREPRODUCTION - FASR REQ.

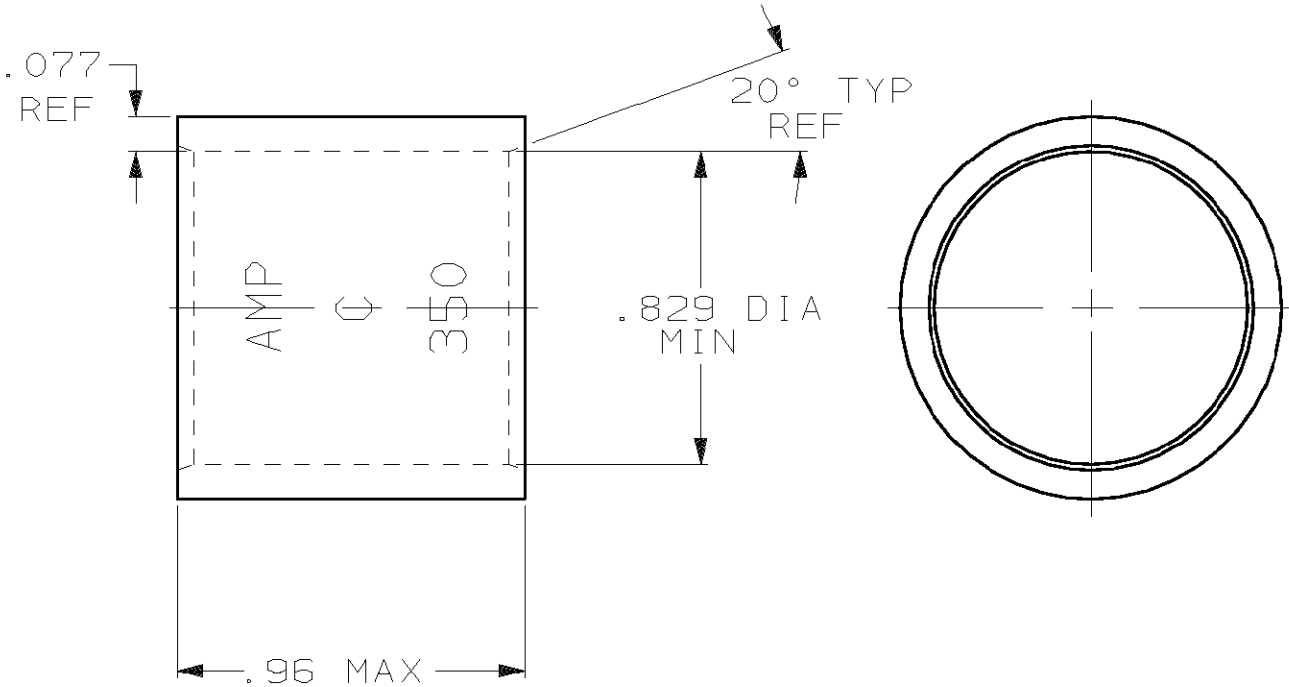

THIS DRAWING IS UNPUBLISHED. RELEASED FOR PUBLICATION BY AMP INCORPORATED. ALL INTERNATIONAL RIGHTS RESERVED. © COPYRIGHT 19

325-375 MCM	①	② 1-324449-0
	TIN PL PER ASTM B 545 .000150 MIN THK	
RANGE	FINISH	PART NO

DO NOT SCALE PRINT. UNLESS SPECIFIED DIMENSIONS IN INCHES TOLERANCES ON: 2 PLC DEC ± - 3 PLC DEC ± - ANGLES ± -	DR 1/16/89 P FORTNEY	AMP INCORPORATED Harrisburg, Pa. 17105	
	CHK 6/20/89 MS FEHER		
	APPD 6/20/89 WJ VOCKROTH	NAME WIRE SPLICE, PARALLEL, AMPOWER, WIRE SIZE: 350 MCM	
	APPD 6/20/89 R ADAMS	SIZE A	FSCM NO 00779
MATERIAL COPPER ASTM-B-75 ANNEALED	PRODUCT SPEC -		
FINISH SEE TABLE	APPLICATION SPEC -	SCALE 2:1	SHEET 1 OF 1
	WEIGHT .068 LB.		