

PART NUMBER	ITEM ① BODY	ITEM ② CONTACT	ITEM ③ INSULATOR	ITEM ④ CRIMP SLEEVE
133-3304-001	BRASS GOLD PL .00001 MIN OVER NICKEL PL .00005 MIN OVER COPPER PL .00005 MIN	BERYLLIUM COPPER GOLD PL .00003 MIN OVER NICKEL PL .00005 MIN OVER COPPER PL .00005 MIN	TEFLON	COPPER GOLD PL .00001 MIN OVER NICKEL PL .00005 MIN OVER COPPER PL .00005 MIN
131-3304-006	BRASS NICKEL PL .0001 MIN OVER COPPER PL .00005 MIN	BERYLLIUM COPPER GOLD PL .00003 MIN OVER NICKEL PL .00005 MIN OVER COPPER PL .00005 MIN	TEFLON	COPPER NICKEL PL .0001 MIN OVER COPPER PL .00005 MIN

DRAWING NO. C - 133-3304-001/010			
0 REVISIONS			
ENGINEERING RELEASE			
1	11-16-95	R H R R R	ECN 43786
RF LEAKAGE: -55 DB WAS -70 5.6 LBS MAX ENGAGE WAS 3.4 LBS. 1.0 / 8.0 LBS DISENGAGE WAS 2.25 / 4.5 CONTACT RETENTION 2.3 LBS WAS 4.0			
* REVISION NUMBER FOLLOWED BY AN ALPHA * * CHARACTER INDICATED DRAWING CLASSIF. * * CATION OR PART NUMBER ADDITION ONLY. *			
10	12-19-00	R H R R R	ECN 47531

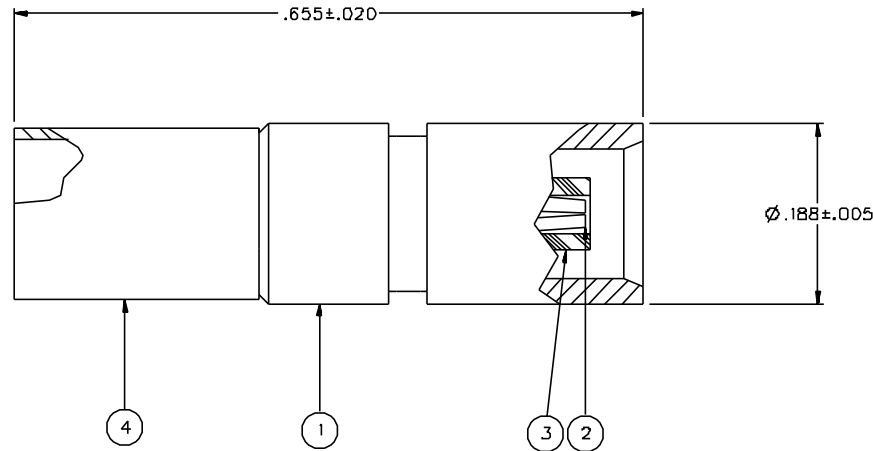

NOTES:

1. SPECIFICATIONS:

IMPEDANCE: 50 OHMS  
 FREQUENCY RANGE: 0-6 GHz  
 VSWR: 1.13-.04F MAX (F IN GHz)  
 WORKING VOLTAGE: 335 VRMS MAX AT SEA LEVEL  
 DIELECTRIC WITHSTANDING VOLTAGE: 1000 VRMS MIN AT SEA LEVEL  
 INSULATION RESISTANCE: 10000 MEGOHM MIN  
 CONTACT RESISTANCE:  
 CENTER CONTACT - INITIAL 5 MILLIOHM MAX, AFTER ENVIRONMENTAL 8 MILLIOHM MAX  
 OUTER CONDUCTOR - GOLD PLATED INITIAL 1 MILLIOHM MAX, AFTER ENVIRONMENTAL 1.5 MILLIOHM MAX  
 NICKEL PLATED INITIAL 2.5 MILLIOHM MAX, AFTER ENVIRONMENTAL 3.5 MILLIOHM MAX  
 BODY TO CABLE - GOLD PLATED INITIAL 1 MILLIOHM MAX, AFTER ENVIRONMENTAL NOT APPLICABLE  
 NICKEL PLATED INITIAL 2.5 MILLIOHMS MAX, AFTER ENVIRONMENTAL NOT APPLICABLE  
 CORONA LEVEL: 250 VOLTS MINIMUM AT 70,000 FEET  
 INSERTION LOSS: .1DB MAX AT 1 GHz  
 RF LEAKAGE: -55 DB AT 2.5 GHz  
 RF HIGH POTENTIAL WITHSTANDING VOLTAGE: 70D VRMS AT 4 AND 7 MHZ

MECHANICAL:

ENGAGE/DISENGAGE FORCE: 5.6 LBS MAX ENGAGEMENT  
 1.0 LB MIN DISENGAGEMENT  
 8.0 LBS MAX DISENGAGEMENT

CONTACT RETENTION FORCE: 2.3 LBS MIN  
 CONTACT RETENTION TORQUE: NOT APPLICABLE  
 COUPLING MECHANISM RETENTION: NOT APPLICABLE  
 CABLE ACCEPTABILITY: RG 188/U DOUBLE SHIELD, RG 316/U DOUBLE SHIELD,  
 RG 178/U DOUBLE SHIELD, RG 187/U DOUBLE SHIELD

CABLE HEX CRIMP SIZE: .151  
 CABLE RETENTION: 25 LBS MIN AXIAL FORCE  
 DURABILITY: 500 CYCLES MIN

ENVIRONMENTAL:

{MEETS OR EXCEEDS THE APPLICABLE PARAGRAPH OF MIL-C-39012}  
 THERMAL SHOCK: MIL-STD-202, METHOD 107, CONDITION F  
 OPERATING TEMPERATURE: -65 DEG C TO 165 DEG C  
 CORROSION: MIL-STD-202, METHOD 101, CONDITION B  
 SHOCK: MIL-STD-202, METHOD 213, CONDITION B  
 VIBRATION: MIL-STD-202, METHOD 204, CONDITION B  
 MOISTURE RESISTANCE: MIL-STD-202, METHOD 106

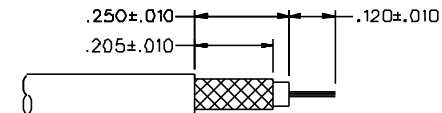

CABLE STRIP DIMENSIONS

4:1

CUSTOMER DRAWING

THIS DRAWING TO BE INTERPRETED PER ANS I 14.5M - 1982

"μSTATION"

COMPANY CONFIDENTIAL

TOLERANCE UNLESS OTHERWISE SPECIFIED		DRAWN BY SWC	DATE 8-16-95	 Cindy Connectivity Solutions 299 Johnson Ave. Ste. 100 Waseca, MN 56093 1-800-247-8256
DECIMALS .XX	mm	CHECKED BY SWC	DATE 11-16-95	
.XXX+-.003		APPROVED BY TAK	DATE 1-2-96	TITLE JACK ASSEMBLY STRAIGHT CABLED, RG 316DS MCX
MATERIAL		APPROVED BY RJB	DATE 1-3-96	CODE NO.
FINISH		RELEASE DATE 1-3-96		DRAWING NO. C - 133-3304-001/010
		SCALE 10:1	U/M INCH	SHEET 2 OF 2