



PFM™ in a VIA Package AC-DC Converter PFM4414xB6M48D0yzz



Isolated AC-DC Converter with PFC

Features & Benefits

- Universal input (85 to 264 V_{AC})
- 48 V_{OUT}, regulated, isolated SELV
- 92% typical efficiency
- Built-in EMI filtering
- Chassis mount or board mount packaging options
- Always-on, self-protecting converter control architecture
- SELV Output
- Two temperature grades including operation to -40°C
- VIA Package
 - Robust Mechanical Design
 - Versatile thermal management capability
- Safe and reliable secondary-side energy storage
- High MTBF
- 140 W/cubic inch power density
- 4414 package
- External rectification and transient protection required

Typical Applications

- Small cell base stations
- Telecom switching equipment
- LED lighting
- Industrial power systems

Part Ordering Information

Product Function	Package Length	Package Width	Package Type	Input Voltage	Range Ratio	Output Voltage (Range)	Max Output Power	Product Grade	Option Field	
PFM	44	14	x	B6	M	48	D0	y	z	z
PFM = Power Factor Module	Length in Inches x 10	Width in Inches x 10	B = Board VIA V = Chassis VIA	Internal Reference				C = -20 to 100°C T = -40 to 100°C	00 = Chassis/Always On 04 = Short Pin/Always On 08 = Long Pin/Always On	

Product Ratings	
V _{IN} = 85 – 264 V	P _{OUT} = up to 400 W
V _{OUT} = 48 V	I _{OUT} = 8.33 A

Product Description

The PFM in a VIA Package is a highly advanced 400 W AC-DC converter operating from a rectified universal AC input which delivers an isolated and regulated Safety Extra Low Voltage (SELV) 48 V secondary output.

This unique, ultra-low profile module incorporates AC-DC conversion, integrated filtering and transient surge protection in a chassis mount or PCB mount form factor.

The PFM enables a versatile two-sided thermal strategy which greatly simplifies thermal design challenges.

When combined with downstream Vicor DC-DC conversion components and regulators, the PFM allows the Power Design Engineer to employ a simple, low-profile design which will differentiate his end-system without compromising on cost or performance metrics.



Size:
4.35 x 1.40 x .37 in
110.6 x 35.5 x 9.3 mm



Typical PCB Mount Applications

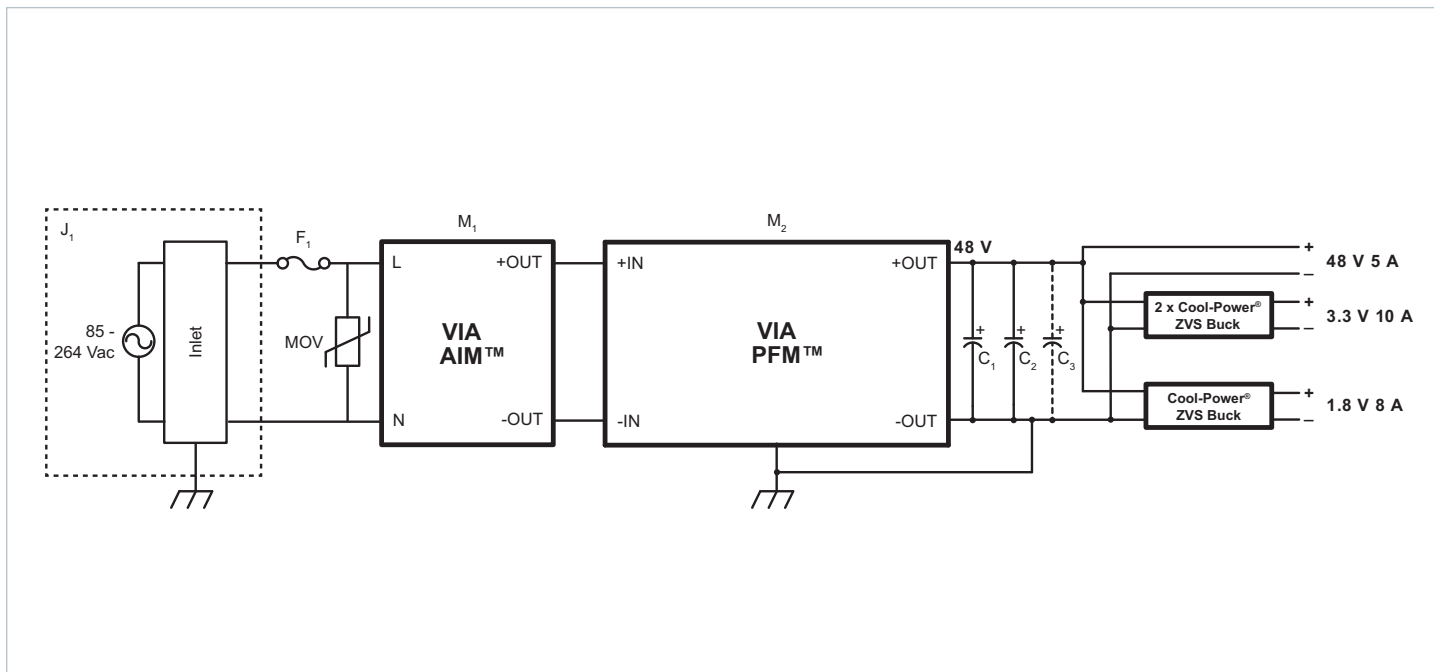

The PCB terminal option allows mounting on an industry standard printed circuit board, with two different pin lengths. Vicor offers a variety of downstream DC-DC converters driven by the 48 V output of the PFM in a VIA package. The 48 V output is usable directly by loads that are tolerant of the PFC line ripple, such as fans, motors, relays, and some types of lighting. Use downstream DC-DC Point of Load converters where more precise regulation is required.

Parts List for Typical PCB Mount Applications	
J1	Qualtek 703 W IEC 320-C14 Power Inlet
F1	Littelfuse 0216008.MXP 8 A 250 VAC 5 x 20 mm holder
M1	Vicor AIM™ AIM1714BB6MC7D5yzz
M2	Vicor PFM™ PFM4414BB6M48D0yzz
C1	Nichicon UVR1J472MRD 4700 µF 63 V 3.4 A 22 x 50 mm bent 90° x 2 pcs or
	CDE 380LX472M063K022 4700 µF 63 V 4.9 A 30 x 30 mm snap x 2 pcs or
	Sic Safco Cubic LP A712121 10,000 µF 63 V 6.4 A 45 x 75 x 12 mm rectangular
MOV	Littelfuse TMOV20RP300E VARISTOR 10 kA 300 V 250 J 20 mm

Typical Chassis Mount Applications

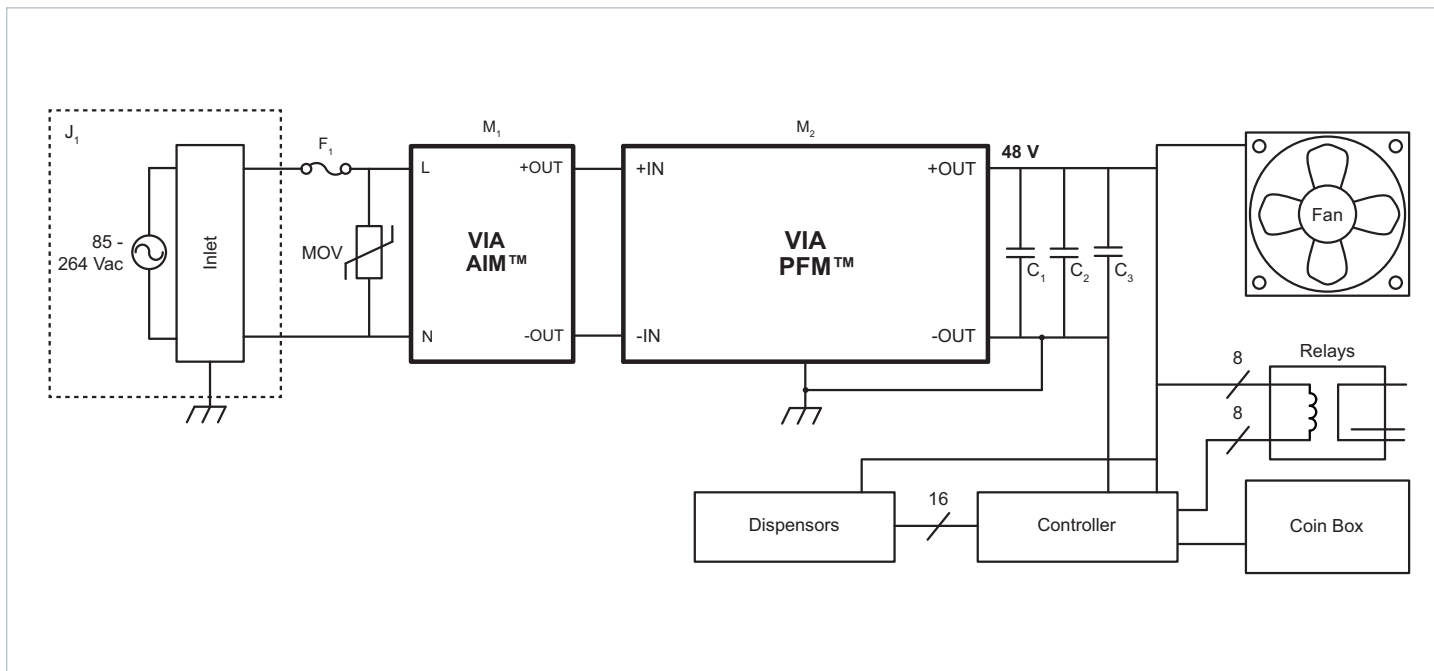

The PFM in a VIA package is available in Chassis Mount option, saving the cost of a PCB and allowing access to both sides of the power supply for cooling. The parts list below minimizes the number of interconnects required between necessary components, and selects components with terminals traditionally used for point to point chassis wiring.

Parts List for Typical Chassis Mount Applications	
J1	Qualtek 719 W or 723 W IEC 320-C14 Power Inlet
F1	Littelfuse 0216008.MXP 8 A 250 VAC 5 x 20 mm in a J1, or separate fuse holder
M1	Vicor AIM™ AIM1714VB6MC7D5y00
M2	Vicor PFM™ PFM4414VB6M48D0y00
C1	UCC E32D630HPN103MA67M 10,000 µF, 63 V 7.4 A, 35 x 67 mm screw terminal or Kemet ALS30A103DE063, 10,000 µF 63 V 10.8 A 36 x 84 mm screw terminal
MOV	Littelfuse TMOV20RP300E VARISTOR 10 kA 300 V 250 J 20 mm

Pin Configuration

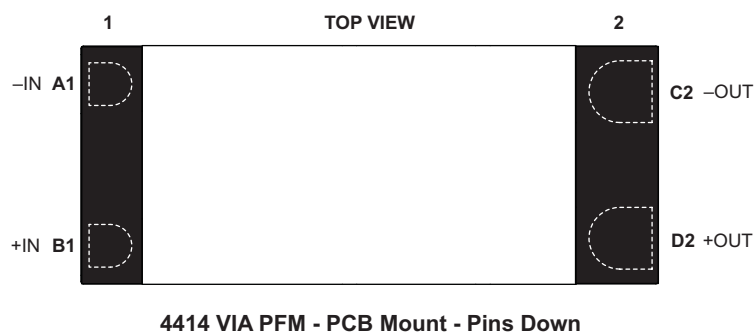
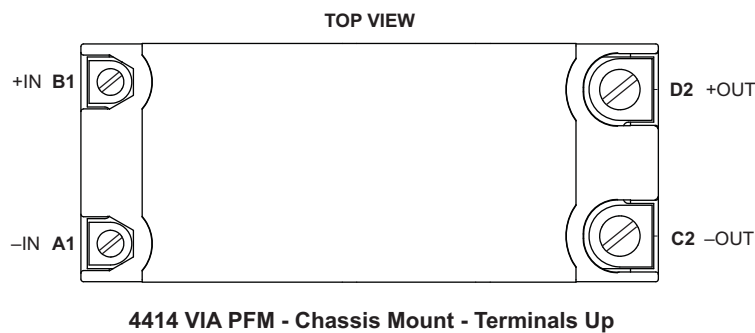

Please note that these Pin drawings are not to scale.

Pin Descriptions

Pin Number	Signal Name	Type	Function
A1	-IN	INPUT POWER RETURN	Negative input power terminal
B1	+IN	INPUT POWER	Positive input power terminal
C2	-OUT	OUTPUT POWER RETURN	Negative output power terminal
D2	+OUT	OUTPUT POWER	Positive output power terminal

Absolute Maximum Ratings

The absolute maximum ratings below are stress ratings only. Operation at or beyond these maximum ratings can cause permanent damage to the device.

Parameter	Comments	Min	Max	Unit
Input voltage +IN to -IN	1 ms max	0	600	Vpk
Input voltage (+IN to -IN)	Continuous, Rectified	0	275	V _{RMS}
Output voltage (+Out to -Out)		-0.5	58	V _{DC}
Output current		0.0	12.4	A
Screw Torque	4 mounting, 2 input, 2 output		4 (0.45)	in/lbs (N-m)
Operating junction temperature	T-Grade	-40	125	°C
Storage temperature	T-Grade	-55	125	°C
Dielectric Withstand*	See note below			
Input-Case	Basic Insulation	2121		Vdc
Input-Output	Reinforced Insulation	4242		Vdc
Output-Case	Functional Insulation	707		Vdc

* Please see Dielectric Withstand section. See page 18.

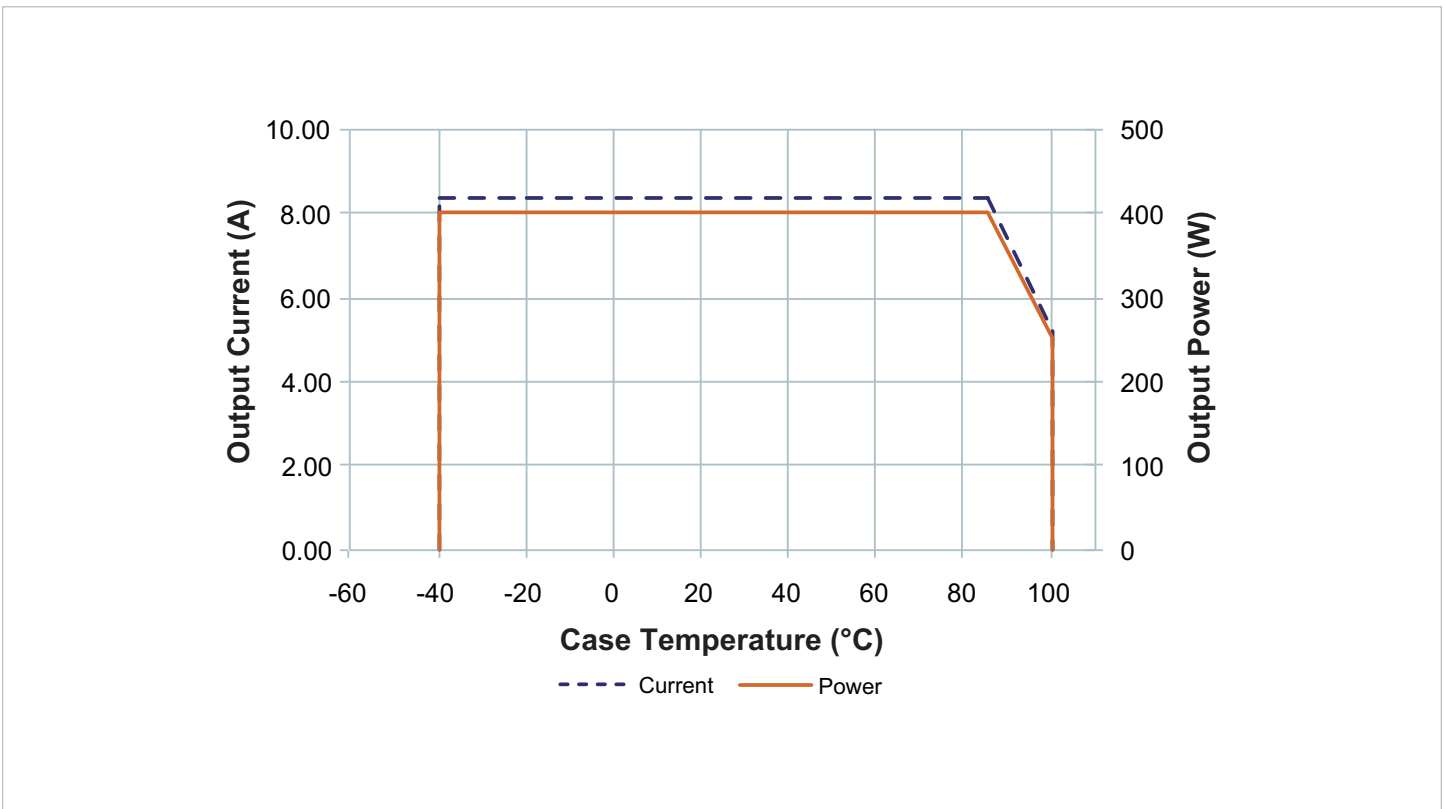

Safe Operating Area

Electrical Specifications

Specifications apply over all line and load conditions, 50 Hz and 60 Hz line frequencies, $T_J = 25^\circ\text{C}$, unless otherwise noted.

Boldface specifications apply over the temperature range of the specified product grade. C_{OUT} is 10,000 μF +/- 20% unless otherwise specified.

Attribute	Symbol	Conditions / Notes	Min	Typ	Max	Unit
Power Input Specification						
Input voltage range, continuous operation	V_{IN}		85		264	V_{RMS}
Input voltage range, transient, non-operational (peak)	V_{IN}	1 ms			600	V
Input voltage cell reconfiguration low-to-high threshold	V_{IN-CR+}			145	148	V_{RMS}
Input voltage cell reconfiguration high-to-low threshold	V_{IN-CR-}		132	135		V_{RMS}
Input current (peak)	I_{INRP}	See Figure 8, Startup Waveforms			12	A
Source line frequency range	f_{line}		47		63	Hz
Power factor	PF	Input power >200 W		0.96		-
Input inductance, maximum	L_{IN}	Differential mode inductance, common mode inductance may be higher. See section "Source Inductance Considerations" on page 15.			1	mH
Input capacitance, maximum	C_{IN}	After bridge rectifier, between +IN and - IN			1.5	μF
No Load Specification						
Input power – no load, maximum	P_{NL}				7	W
Power Output Specification						
Output voltage set point	V_{OUT}	$V_{IN} = 230 V_{rms}$, 100% Load	46	48	50	V
Output voltage, no load	V_{OUT-NL}	Over all operating steady state line conditions	42		54	V
Output voltage range (transient)	V_{OUT}	Non-faulting abnormal line and load transient conditions	30		57.6	V
Output power	P_{OUT}	See SOA on Page 5			400	W
Efficiency	η	$V_{IN} = 230 V$, full load, exclusive of input rectifier losses	90.5	92		%
		$85 V < V_{IN} < 264 V$, full load, exclusive of input rectifier losses	90			%
		$85 V < V_{IN} < 264 V$, 75% load, exclusive of input rectifier losses	90			%
Output voltage ripple, switching frequency	$V_{OUT-PP-HF}$	Over all operating steady-state line and load conditions, 20 MHz BW, measured at C3, Figure 5		200	2000	mV
Output voltage ripple line frequency	$V_{OUT-PP-LF}$	Over all operating steady-state line and load conditions, 20 MHz BW		3.0	7.0	V
Output capacitance (external)	$C_{OUT-EXT}$	Allows for $\pm 20\%$ capacitor tolerance	6800		15000	μF
Output turn-on delay	T_{ON}	From V_{IN} applied		500	1000	ms
Start-up setpoint acquisition time	T_{SS}	Full load		500	1000	ms
Cell reconfiguration response time	T_{CR}	Full load		5.5	11	ms
Voltage deviation (transient)	$\%V_{OUT-TRANS}$		-37.5		20	%
Recovery time	T_{TRANS}			300	600	ms
Line regulation	$\%V_{OUT-LINE}$	Full load			3	%
Load regulation	$\%V_{OUT-LOAD}$	10% to 100% load			3	%
Output current (continuous)	I_{OUT}	SOA			8.33	A
Output current (transient)	I_{OUT-PK}	20 ms duration, average power $\leq P_{OUT, max}$			12.5	A

Electrical Specifications (Cont.)

Specifications apply over all line and load conditions, 50 Hz and 60 Hz line frequencies, $T_J = 25^\circ\text{C}$, unless otherwise noted.

Boldface specifications apply over the temperature range of the specified product grade. C_{OUT} is 10,000 μF +/- 20% unless otherwise specified.

Attribute	Symbol	Conditions / Notes	Min	Typ	Max	Unit
Powertrain Protections						
Input undervoltage turn-on	$V_{IN-UVLO+}$	See Timing Diagram		74	83	V_{RMS}
Input undervoltage turn-off	$V_{IN-UVLO-}$		65	71		V_{RMS}
Input overvoltage turn-on	$V_{IN-UVLO-}$	See Timing Diagram	265	270		V_{RMS}
Input overvoltage turn-off	$V_{IN-UVLO+}$			273	287	V_{RMS}
Output overvoltage threshold	$V_{OUT-UVLO+}$	Instantaneous, latched shutdown	58	61	64	V
Upper start / restart temperature threshold (case)	$T_{CASE-OTP-}$		100			$^\circ\text{C}$
Overtemperature shutdown threshold (junction)	T_{J-OTP+}			125		$^\circ\text{C}$
Overtemperature shutdown threshold (case)	$T_{CASE-OTP+}$			110		$^\circ\text{C}$
Overcurrent blanking time	T_{OC}	Based on line frequency	400	460	550	ms
Input overvoltage response time	T_{POVP}			40		ms
Input undervoltage response time	T_{UVLO}	Based on line frequency		200		ms
Output overvoltage response time	T_{SOVP}	Powertrain on		30		ms
Short circuit response time	T_{SC}	Powertrain on, operational state		270		μs
Fault retry delay time	T_{OFF}	See Timing Diagram		10		s
Output power limit	P_{PROT}	50% overload for 20 ms typ allowed	400			W

Timing diagram

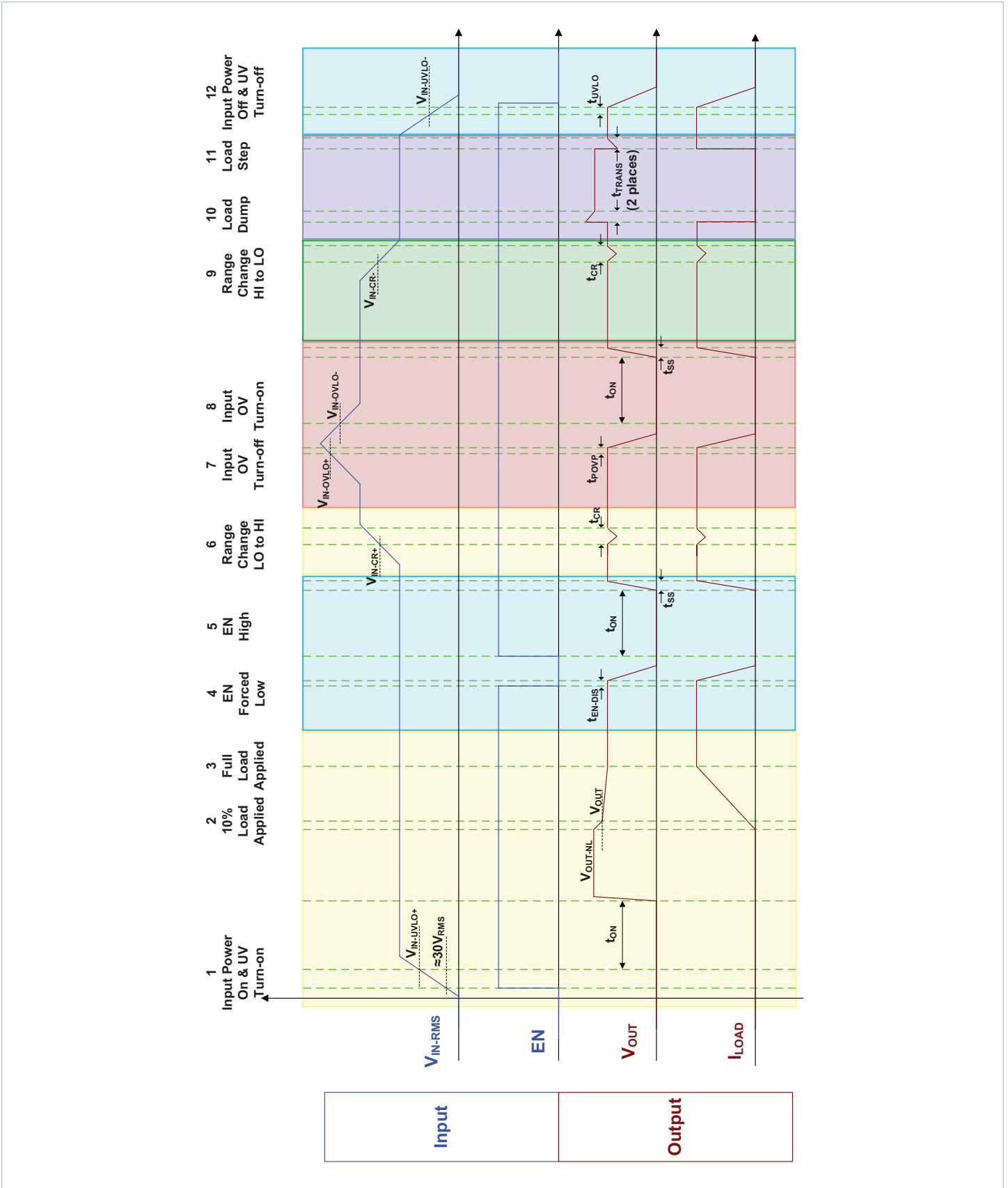

Timing diagram (Cont.)

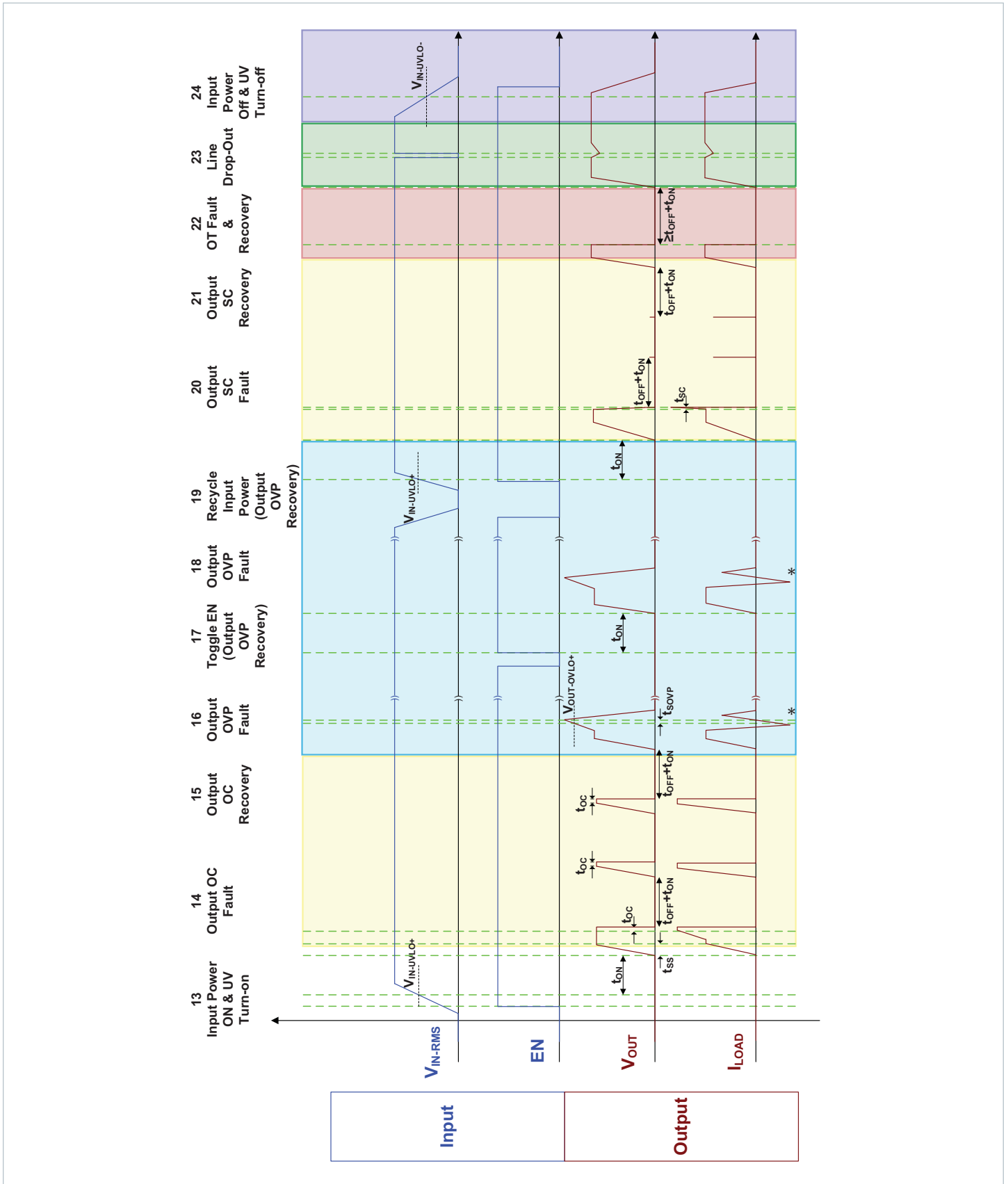

Application Characteristics

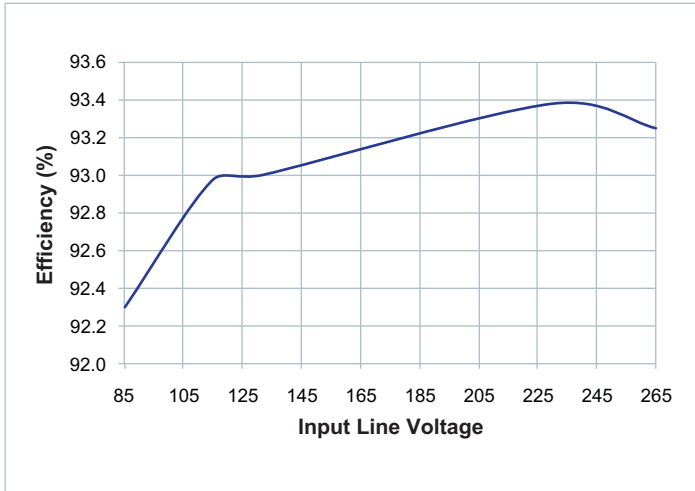

Figure 1 — Full load efficiency vs. line voltage

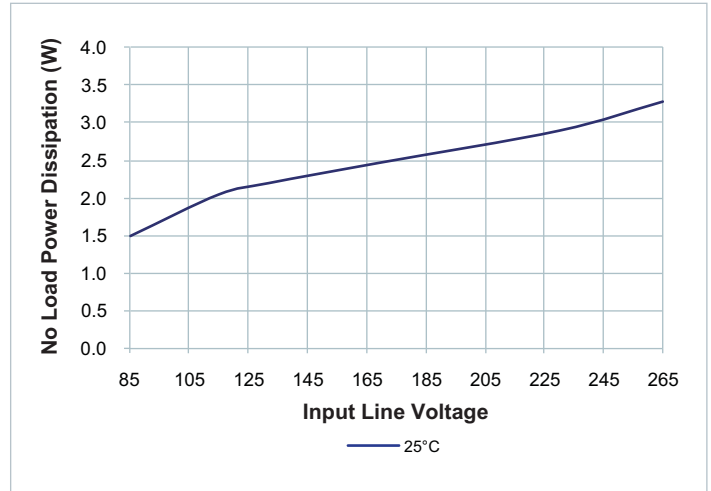

Figure 2 — Typical no load power dissipation vs. V_{IN} , module enabled

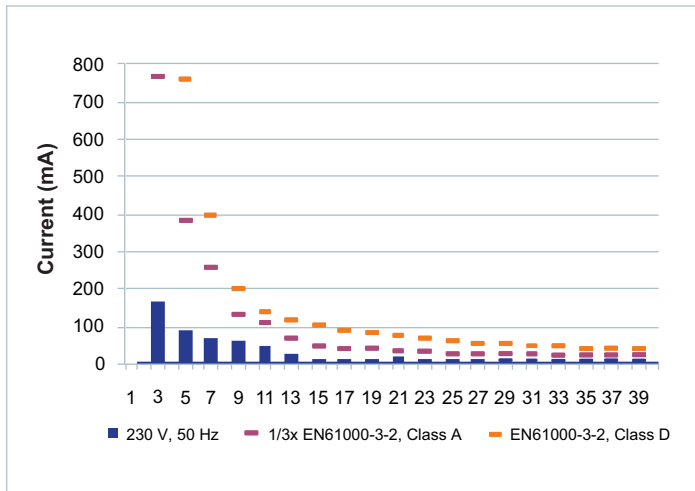

Figure 3 — Typical input current harmonics, full load vs. V_{IN} using typical applications circuit on pages 2 & 3

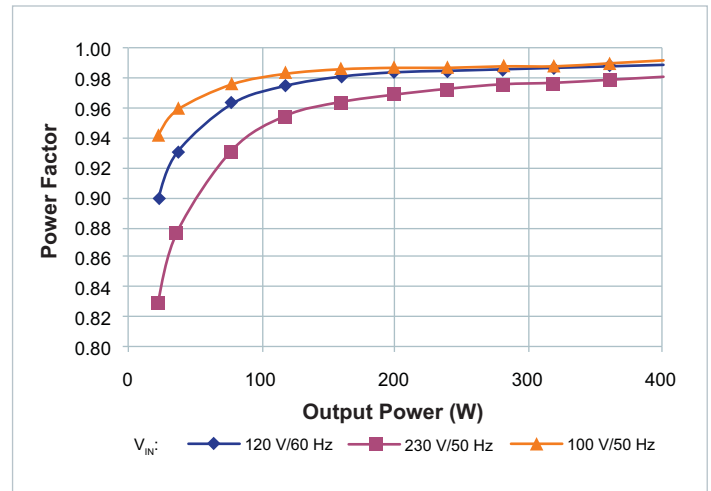

Figure 4 — Typical power factor vs. V_{IN} and I_{OUT} using typical applications circuit on pages 2 & 3

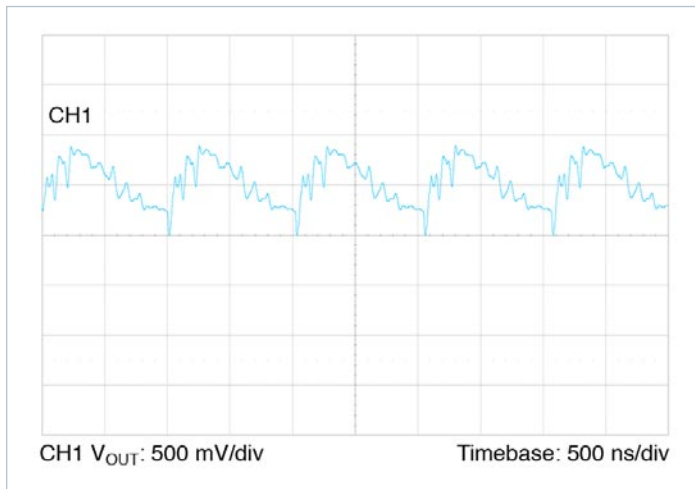

Figure 5 — Typical switching frequency output voltage ripple waveform, $T_{CASE} = 30^{\circ}C$, $V_{IN} = 230 V$, $I_{OUT} = 8.3 A$, no external ceramic capacitance, 20 MHz BW

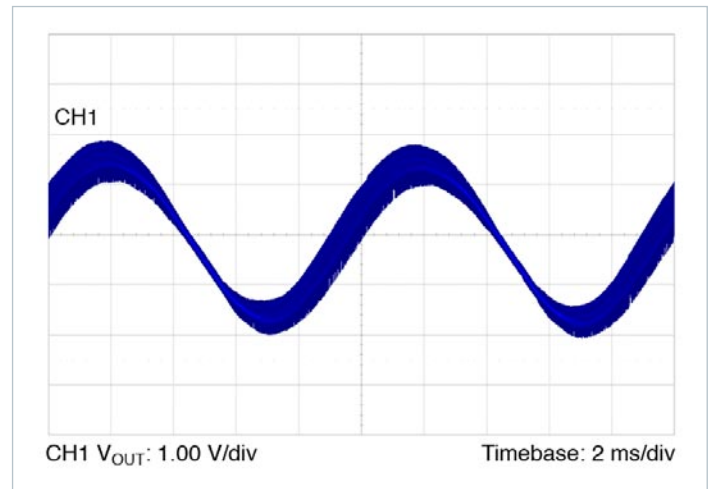

Figure 6 — Typical line frequency output voltage ripple waveform, $T_{CASE} = 30^{\circ}C$, $V_{IN} = 230 V$, $I_{OUT} = 8.3 A$, $C_{OUT} = 10,000 \mu F$, 20 MHz BW

Application Characteristics (Cont.)

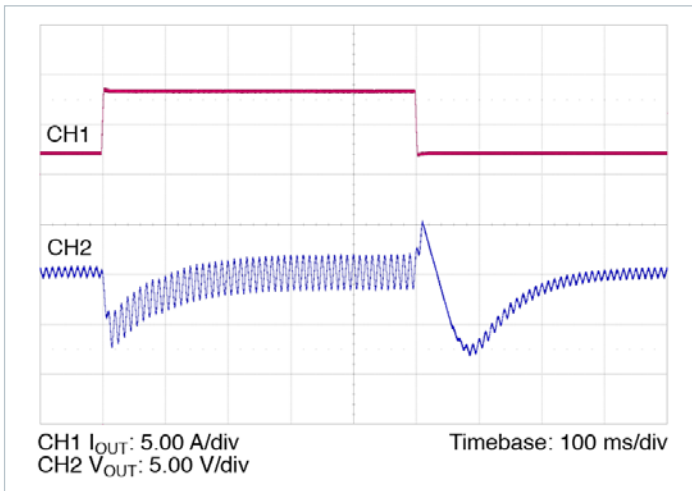

Figure 7 — Typical output voltage transient response, $T_{CASE} = 30^{\circ}C$, $V_{IN} = 230 V$, $I_{OUT} = 8.3 A$, $2.1 A$
 $C_{OUT} = 10,000 \mu F$

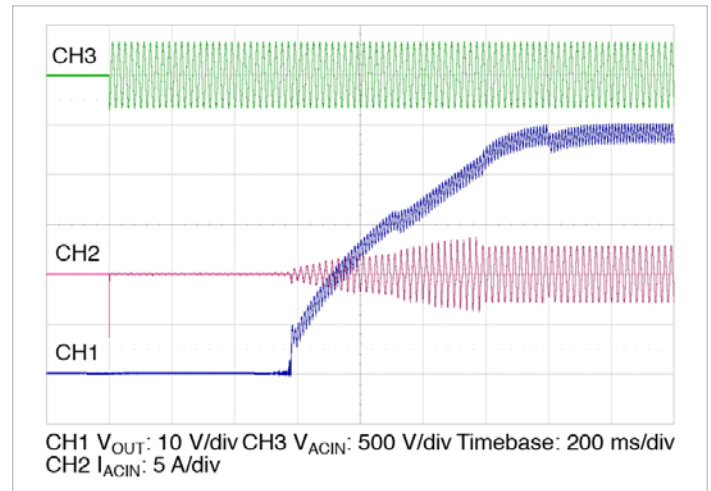

Figure 8 — Typical startup waveform, application of V_{IN} , $I_{OUT} = 8.3 A$, $C_{OUT} = 10,000 \mu F$

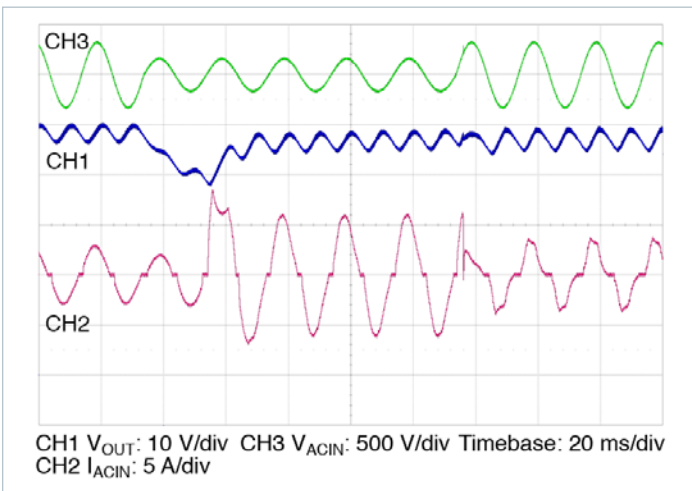

Figure 9 — 230 V, 120 V range change transient response, $I_{OUT} = 8.3 A$, $C_{OUT} = 10,000 \mu F$

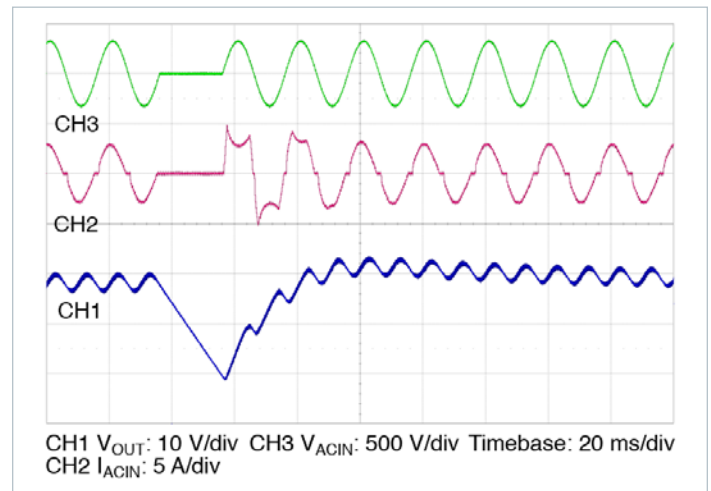

Figure 10 — Line drop out, 230 V 50 Hz, 0° phase, $I_{OUT} = 8.3 A$, $C_{OUT} = 10,000 \mu F$

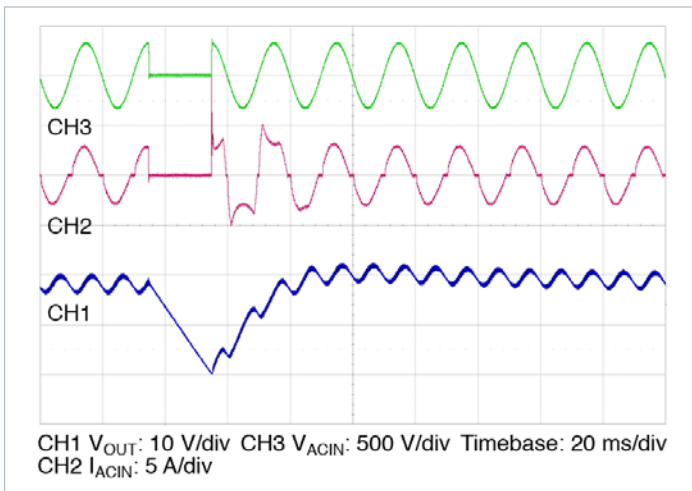

Figure 11 — Line drop out, 90° phase, $V_{IN} = 230 V$, $I_{OUT} = 8.3 A$, $C_{OUT} = 10,000 \mu F$

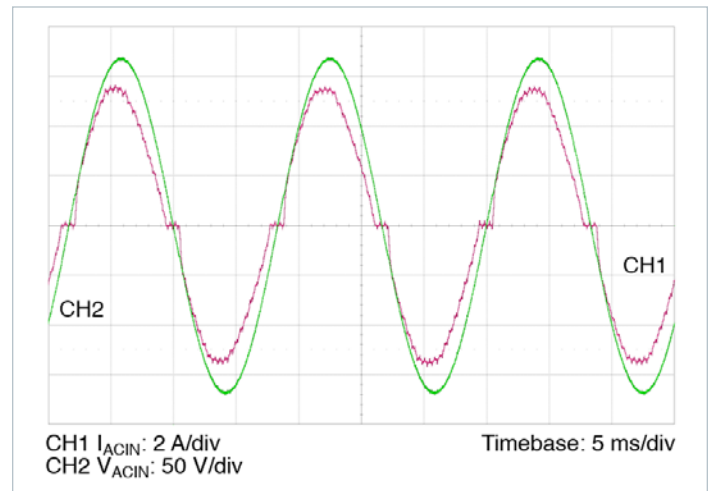

Figure 12 — Typical line current waveform, $V_{IN} = 120 V$, 60 HZ $I_{OUT} = 8.3 A$, $C_{OUT} = 10,000 \mu F$

Application Characteristics (Cont.)

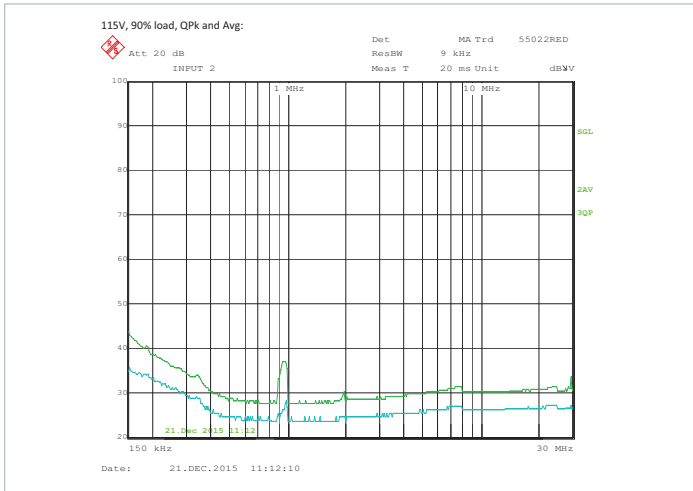

Figure 13 — Typical EMI Spectrum, Peak Scan, 90% load, 115 V_{IN} , $C_{OUT} = 10,000 \mu F$ using Typical Chassis Mount Application Circuit

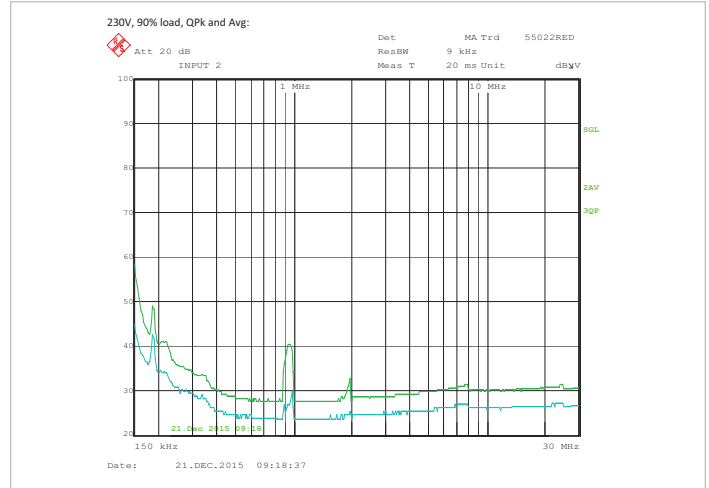

Figure 14 — Typical EMI Spectrum, Peak Scan, 90% load, 230 V_{IN} , $C_{OUT} = 10,000 \mu F$ using Typical Chassis Mount Application Circuit

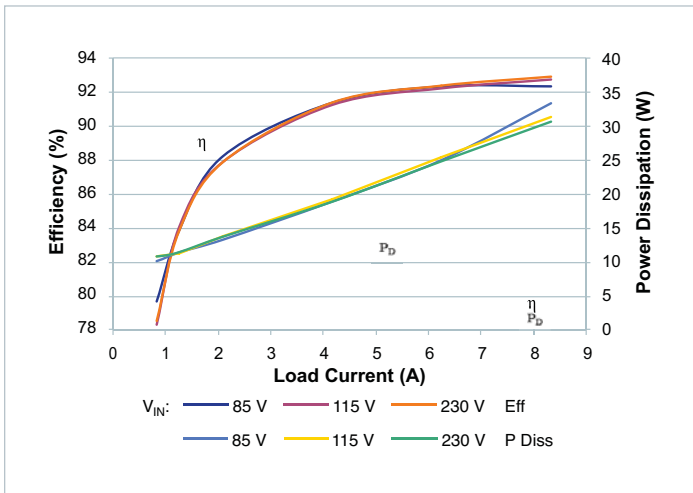

Figure 15 — V_{IN} to V_{OUT} efficiency and power dissipation vs. V_{IN} and I_{OUT} , $T_{CASE} = -40^{\circ}C$

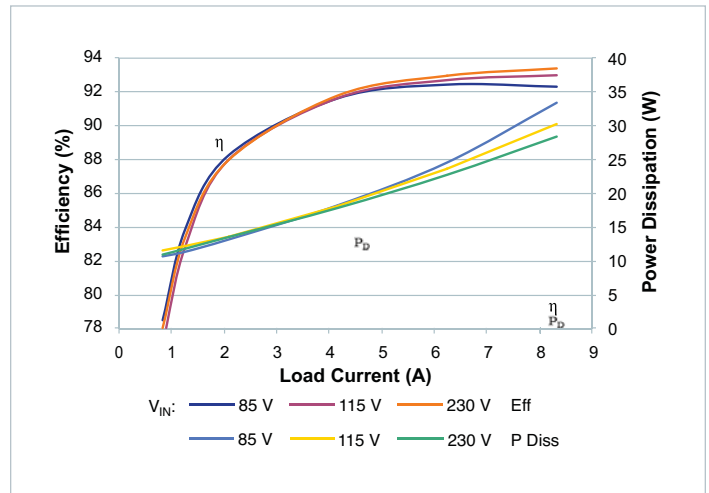

Figure 16 — V_{IN} to V_{OUT} efficiency and power dissipation vs. V_{IN} and I_{OUT} , $T_{CASE} = 20^{\circ}C$

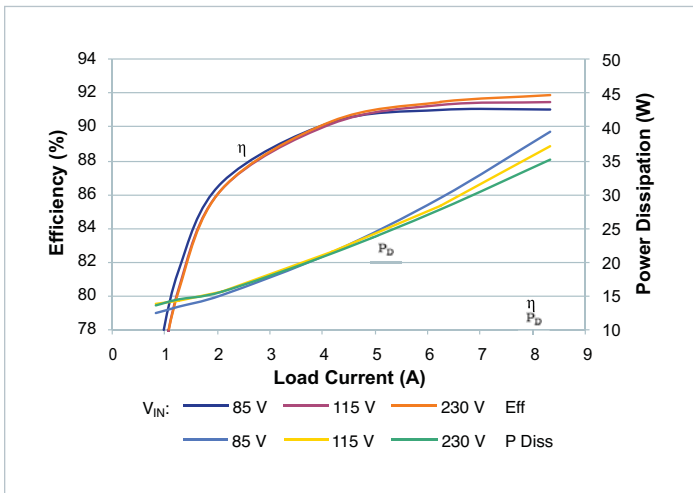

Figure 17 — V_{IN} to V_{OUT} efficiency and power dissipation vs. V_{IN} and I_{OUT} , $T_{CASE} = 80^{\circ}C$

General Characteristics

Specifications apply over all line and load conditions, 50 Hz and 60 Hz line frequencies, TC = 25°C, unless otherwise noted.

Boldface specifications apply over the temperature range of the specified Product Grade.

Attribute	Symbol	Conditions / Notes	Min	Typ	Max	Unit
Mechanical						
Length	L			110.6 / [4.35]		mm / [in]
Width	W			35.5 / [1.40]		mm / [in]
Height	H			9.3 / [0.37]		mm / [in]
Volume	Vol	Without heatsink		36.9 / [2.25]		cm ³ / [in ³]
Weight	W			148 / [5.2]		g / [oz]
Pin material		C145 copper, half hard				
Underplate		Low stress ductile nickel	50		100	µin
Pin finish		Palladium	0.8		6	µin
		Soft Gold	0.12		2	µin
Thermal						
Operating case temperature	T _C	C - Grade, see derating curve in SOA	-20		100	°C
		T - Grade, see derating curve in SOA	-40		100	°C
Thermal resistance, junction to case, top	R _{JC_TOP}			1.34		°C/W
Thermal resistance, junction to case, bottom	R _{JC_BOT}			1.72		°C/W
Coupling thermal resistance, top to bottom of case, internal	R _{HOU}			0.57		°C/W
Shell Thermal capacity				54		J/K
Thermal design		See Thermal Design on Page 17				
Assembly						
ESD rating	ESD _{HBM}	Human Body Model, JEDEC JESD 22-A114C.01	1,000			V
	ESD _{MM}	Machine Model, JEDEC JESD 22-A115B	N/A			
	ESD _{CDM}	Charged Device Model, JEDEC JESD 22-C101D	200			
Safety						
Agency approvals/standards		cTUVus, EN60950-1 and IEC 60950-1				
		cURus, UL 60950-1 and CAN/CSA 60950-1				
		CE Marked for Low Voltage Directive and RoHS Recast Directive, as applicable				
		Touch Current measured in accordance with IEC 60990 using measuring network Figure 3 (PFM in a VIA package only)		0.5		mA

General Characteristics (Cont.)

Specifications apply over all line and load conditions, 50 Hz and 60 Hz line frequencies, TC = 25°C, unless otherwise noted.

Boldface specifications apply over the temperature range of the specified Product Grade.

Attribute	Symbol	Conditions / Notes	Min	Typ	Max	Unit
EMI/EMC Compliance (Pending)						
FCC Part 15, EN55022, CISPR22: 2006 + A1: 2007, Conducted Emissions		Class B Limits - with –OUT connected to GND				
EN61000-3-2: 2009, Harmonic Current Emissions		Class A				
EN61000-3-3: 2005, Voltage Changes & Flicker		$P_{ST} < 1.0$; $P_{LT} < 0.65$; dc < 3.3% $d_{max} < 6\%$				
EN61000-4-4: 2004, Electrical Fast Transients		Level 2, Performance Criteria A				
EN61000-4-5: 2006, Surge Immunity		Level 3, Immunity Criteria A, external TMOV required				
EN61000-4-6: 2009, Conducted RF Immunity		Level 2, 130 dB μ V (3.0 V _{RMS})				
EN61000-4-8: 1993 + A1 2001, Power Frequency H-Field 10A/m, continuous field		Level 3, Performance Criteria A				
EN61000-4-11: 2004, Voltage Dips & Interrupts		Class 2, Performance Criteria A Dips, Performance Criteria B Interrupts				

Reliability						
Case	Reliability Assurance Relex Modeling , Studio 2007,v2]	Temp (°C)	Duty Cycle	Condition	MTBF (MHrs)	FIT
1	Telcordia Issue 2, Method I Case 1	25	100%	GB,GC	0.702	1424
2	MIL-HDBK-217FN2 Parts Count - 25°C Ground Benign, Stationary, Indoors / Computer	25	100%	GB,GC	0.322	3102
3	Telcordia Issue 2, Method I Case 3	25	100%	GB,GC	2.43	412

Product Details and Design Guidelines

Building Blocks and System Designs

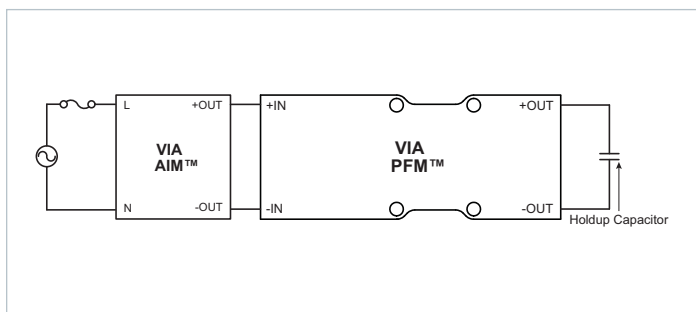

Figure 18 – 400 W Universal AC-to-DC Supply

The VIA PFM is a high efficiency AC-to-DC converter, operating from a universal AC input to generate an isolated SELV 48 VDC output bus with power factor correction. It is the key component of an AC-to-DC power supply system such as the one shown in Figure 18 above.

The input to the VIA PFM is a rectified sinusoidal AC source with a power factor maintained by the module with harmonics conforming to IEC 61000-3-2. Internal filtering enables compliance with the standards relevant to the application (Surge, EMI, etc.). See EMI/EMC Compliance standards on Page 14.

The module uses secondary-side energy storage (at the SELV 48 V bus) to maintain output hold up through line dropouts and brownouts. Downstream regulators also provide tighter voltage regulation, if required.

Traditional PFC Topology

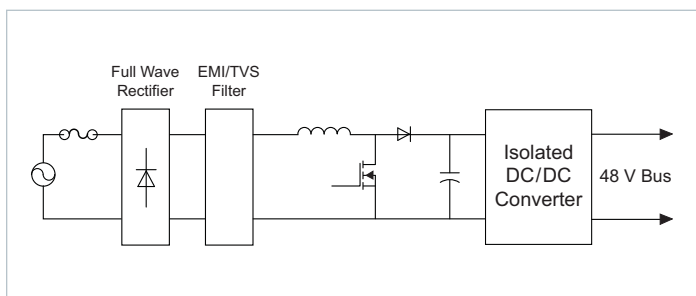

Figure 19 – Traditional PFC AC-to-DC supply

To cope with input voltages across worldwide AC mains (85 – 264 Vac), traditional AC-DC power supplies (Figure 19) use two power conversion stages: 1) a PFC boost stage to step up from a rectified input as low as 85 Vac to ~380 Vdc; and 2) a DC-DC down converter from 380 Vdc to a 48 V bus.

The efficiency of the boost stage and of traditional power supplies is significantly compromised operating from worldwide AC lines as low as 85 Vac.

Adaptive Cell™ Topology

With its single stage Adaptive Cell™ topology, the VIA PFM enables consistently high efficiency conversion from worldwide AC mains to a 48 V bus and efficient secondary-side power distribution.

Input Fuse Selection

PFM in a VIA package products are not internally fused in order to provide flexibility in configuring power systems. Input line fusing is recommended at system level, in order to provide thermal protection in case of catastrophic failure. The fuse shall be selected by closely matching system requirements with the following characteristics:

- Recommended fuse: 216 Series Littelfuse 8A or lower current rating (usually greater than the PFM maximum current at lowest input voltage)
- Maximum voltage rating (usually greater than the maximum possible input voltage)
- Ambient temperature
- Breaking capacity per application requirements
- Nominal melting I^2t

Source Inductance Considerations

The PFM Powertrain uses a unique Adaptive Cell Topology that dynamically matches the powertrain architecture to the AC line voltage. In addition the PFM uses a unique control algorithm to reduce the AC line harmonics yet still achieve rapid response to dynamic load conditions presented to it at the DC output terminals. Given these unique power processing features, the PFM can expose deficiencies in the AC line source impedance that may result in unstable operation if ignored.

It is recommended that for a single PFM, the line source inductance should be no greater than 1 mH for a universal AC input of 100 - 240 V. If the PFM will be operated at 240 V nominal only, the source impedance may be increased to 2 mH. For either of the preceding operating conditions it is best to be conservative and stay below the maximum source inductance values. When multiple PF's are used on a single AC line, the inductance should be no greater than 1 mH/N, where N is the number of PFM's on the AC branch circuit, or 2 mH/N for 240 Vac operation. It is important to consider all potential sources of series inductance including and not limited to, AC power distribution transformers, structure wiring inductance, AC line reactors, and additional line filters. Non-linear behavior of power distribution devices ahead of the PFM may further reduce the maximum inductance and require testing to ensure optimal performance.

If the PFM is to be utilized in large arrays, thePFMs should be spread across multiple phases or sources thereby minimizing the source inductance requirements, or be operated at a line voltage close to 240 Vac. Vicor Applications should be contacted to assist in the review of the application when multiple devices are to be used in arrays.

Fault Handling

Input Undervoltage (UV) Fault Protection

The input voltage is monitored by the micro-controller to detect an input under voltage condition. When the input voltage is less than the $V_{IN-UVLO-}$, a fault is detected, the fault latch and reset logic disables the modulator, the modulator stops powertrain switching, and the output voltage of the unit falls. After a time t_{UVLO} , the unit shuts down. Faults lasting less than t_{UVLO} may not be detected. Such a fault does not go through an auto-restart cycle. Once the input voltage rises above $V_{IN-UVLO+}$, the unit recovers from the input UV fault, the powertrain resumes normal switching after a time t_{ON} and the output voltage of the unit reaches the set-point voltage within a time t_{SS} .

Overcurrent (OC) Fault Protection

The unit’s output current, determined by V_{EAO} , V_{IN_B} and the primary-side sensed output voltage is monitored by the microcontroller to detect an output OC condition. If the output current exceeds its current limit, a fault is detected, the reset logic disables the modulator, the modulator stops powertrain switching, and the output voltage of the module falls after a time t_{OC} . As long as the fault persists, the module goes through an auto-restart cycle with off time equal to $t_{OFF} + t_{ON}$ and on time equal to t_{OC} . Faults shorter than a time t_{OC} may not be detected. Once the fault is cleared, the module follows its normal start up sequence after a time t_{OFF} .

Short Circuit (SC) Fault Protection

The microcontroller determines a short circuit on the output of the unit by measuring its primary sensed output voltage and EAO. Most commonly, a drop in the primary-sensed output voltage triggers a short circuit event. The module responds to a short circuit event within a time t_{SC} . The module then goes through an auto restart cycle, with an off time equal to $t_{OFF} + t_{ON}$ and an on time equal to t_{SC} , for as long as the short circuit fault condition persists. Once the fault is cleared, the unit follows its normal start up sequence after a time t_{OFF} . Faults shorter than a time t_{SC} may not be detected.

Temperature Fault Protection

The microcontroller monitors the temperature within the PFM . If this temperature exceeds T_{J_OTP+} , an overtemperature fault is detected, the reset logic block disables the modulator, the modulator stops the powertrain switching and the output voltage of the PFM falls. Once the case temperature falls below T_{CASE_OTP-} , after a time greater than or equal to t_{OFF} , the converter recovers and undergoes a normal restart. For the C-grade version of the converter, this temperature is 75°C. Faults shorter than a time t_{OTP} may not be detected. If the temperature falls below T_{CASE_UTP-} , an undertemperature fault is detected, the reset logic disables the modulator, the modulator stops powertrain switching and the output voltage of the unit falls. Once the case temperature rises above T_{CASE_UTP} , after a time greater than or equal to t_{OFF} , the unit recovers and undergoes a normal restart.

Output Overvoltage Protection (OVP)

The microcontroller monitors the primary sensed output voltage to detect output OVP. If the primary sensed output voltage exceeds V_{OUT_OVLO+} , a fault is latched, the logic disables the modulator, the modulator stops powertrain switching, and the output voltage of the module falls after a time t_{SOVP} . Faults shorter than a time t_{SOVP} may not be detected. This type of fault is a latched fault and requires that 1) the EN pin be toggled or 2) the input power be recycled to recover from the fault.

Hold-up Capacitance

The VIA PFM uses secondary-side energy storage (at the SELV 48 V bus) and optional PRM® regulators to maintain output hold up through line dropouts and brownouts. The module’s output bulk capacitance can be sized to achieve the required hold up functionality.

Hold-up time depends upon the output power drawn from the VIA PFM based AC-to-DC front end and the input voltage range of downstream DC-to-DC converters.

The following formula can be used to calculate hold-up capacitance for a system comprised of PFM and a downstream regulator:

Output Filtering

The VIA PFM requires an output bulk capacitor in the range of 6,800 μ F

$$C = 2 * P_{OUT} * (0.005 + t_d) / (V_2^2 - V_1^2)$$

where:

- C VIA PFM’s output bulk capacitance in farads
- t_d Hold-up time in seconds
- P_{OUT} VIA PFM’s output power in watts
- V_2 Output voltage of VIA PFM’s converter in volts
- V_1 Downstream regulator undervoltage turn off (volts)
- OR–
- P_{OUT} / I_{OUT-PK} , whichever is greater.

to 15,000 μ F for proper operation of the PFC front-end. A minimum 10,000 μ F is recommended for full rated output. Capacitance can be reduced proportionally for lower maximum loads.

The output voltage has the following two components of voltage ripple:

- 1) Line frequency voltage ripple: $2 * f_{LINE}$ Hz component
- 2) Switching frequency voltage ripple: 1 MHz module switching frequency component (see Figure 5).

Line Frequency Filtering

Output line frequency ripple depends upon output bulk capacitance. Output bulk capacitor values should be calculated based on line frequency voltage ripple. High-grade electrolytic capacitors with adequate ripple current ratings, low ESR and a minimum voltage rating of 63 V are recommended.

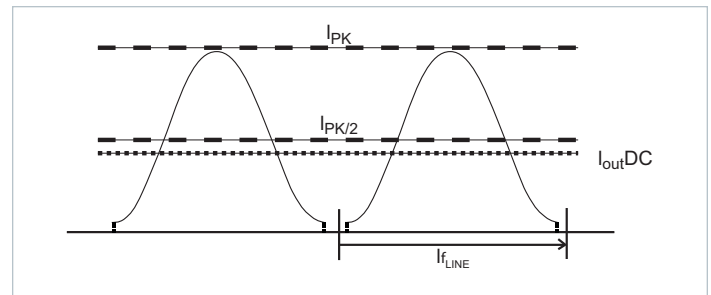

Figure 20 – Output current waveform

Based on the output current waveform, as seen in Figure 20, the following formula can be used to determine peak-to-peak line frequency output voltage ripple:

$$V_{ppl} \cong 0.2 * P_{OUT} / (V_{OUT} * f_{LINE} * C)$$

where:

- V_{ppl} Output voltage ripple Peak-to-peak line frequency
- P_{OUT} Average output power
- V_{OUT} Output voltage set point, nominally 48 V
- f_{LINE} Frequency of line voltage
- C Output bulk capacitance
- I_{DC} Maximum average output current
- I_{PK} Peak-to-peak line frequency output current ripple

In certain applications, the choice of bulk capacitance may be determined by hold-up requirements and low frequency output voltage filtering requirements. Such applications may use the greater capacitance value determined from these requirements. The ripple current rating for the bulk capacitors can be determined from the following equation:

$$I_{ripple} \cong 0.8 * P_{OUT} / V_{OUT}$$

Switching Frequency Filtering

This is included within the VIA PFM. No external filtering is necessary for most applications. For the most noise sensitive applications, a common mode choke followed by two caps to PE GND will reduce switching noise further.

EMI Filtering and Transient Voltage Suppression

EMI Filtering

The PFM with PFC is designed such that it will comply with EN55022 Class B for Conducted Emissions with the Vicor AIM, AIM1714xB6MC7D5yzz. The emissions spectrum is shown in Figures 13 & 14. If the positive output is connected to earth ground, a 4700 pF 500 V capacitor on the -OUT terminal to ground is also recommended.

EMI performance is subject to a wide variety of external influences such as PCB construction, circuit layout etc. As such, external components in addition to those listed herein may be required in specific instances to gain full compliance to the standards specified.

Transient Voltage Suppression

The PFM contains line transient suppression circuitry to meet specifications for surge (i.e. EN61000-4-5) and fast transient conditions (i.e. EN61000-4-4 fast transient/“burst”).

Thermal Considerations

The VIA™ package provides effective conduction cooling from either of the two module surfaces. Heat may be removed from the top surface, the bottom surface or both. The extent to which these two surfaces are cooled is a key component for determining the maximum power that can be processed by a VIA™, as can be seen from specified thermal operating area on Page 5. Since the VIA has a maximum internal temperature rating, it is necessary to estimate this internal temperature based on a system-level thermal solution. To this purpose, it is helpful

to simplify the thermal solution into a roughly equivalent circuit where power dissipation is modeled as a current source, isothermal surface temperatures are represented as voltage sources and the thermal resistances are represented as resistors. Figure 21 shows the “thermal circuit” for the VIA module.

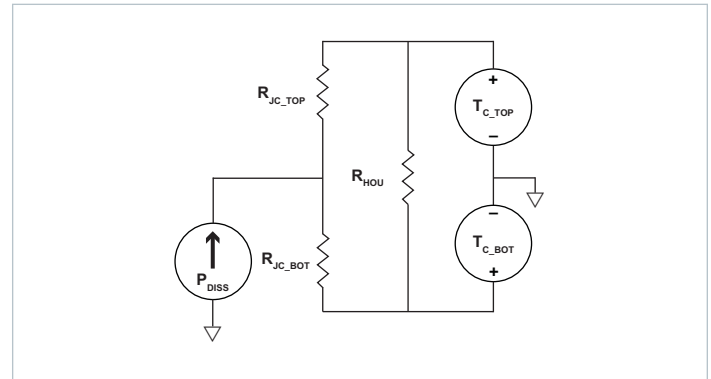

Figure 21 – Double sided cooling VIA thermal model

In this case, the internal power dissipation is PDISS, RJC_TOP and RJC_BOT are thermal resistance characteristics of the VIA module and the top and bottom surface temperatures are represented as Tc_TOP and Tc_BOT. It is interesting to notice that the package itself provides a high degree of thermal coupling between the top and bottom case surfaces (represented in the model by the resistor RHOU). This feature enables two main options regarding thermal designs:

- Single side cooling: the model of Figure 21 can be simplified by calculating the parallel resistor network and using one simple thermal resistance number and the internal power dissipation curves; an example for bottom side cooling only is shown in Figure 22.

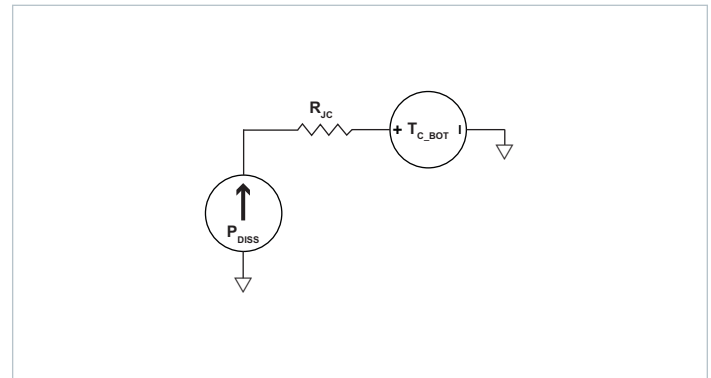

Figure 22 – Single-sided cooling VIA thermal model

In this case, RJC can be derived as following:

$$R_{JC} = \frac{(R_{JC_TOP} + R_{HOU}) * R_{JC_BOT}}{R_{JC_TOP} + R_{HOU} + R_{JC_BOT}}$$

- Double side cooling: while this option might bring limited advantage to the module internal components (given the surface-to-surface coupling provided), it might be appealing in cases where the external thermal system requires allocating power to two different elements, like for example heatsinks with independent airflows or a combination of chassis/air cooling.

Powering a Constant Power Load

When the output voltage of the VIA PFM module is applied to the input of the downstream regulator, the regulator turns on and acts as a constant-power load. When the module's output voltage reaches the input undervoltage turn on of the regulator, the regulator will attempt to start. However, the current demand of the downstream regulator at the undervoltage turn-on point and the hold-up capacitor charging current may force the VIA PFM into current limit. In this case, the unit may shut down and restart repeatedly. In order to prevent this multiple restart scenario, it is necessary to delay enabling a constant-power load when powered up by the upstream VIA PFM until after the output set point of the VIA PFM is reached.

This can be achieved by

1. keeping the downstream constant-power load off during power up sequence
- and
2. turning the downstream constant-power load on after the output voltage of the module reaches 48 V steady state

After the initial startup, the output of the PFM can be allowed to fall to 30 V during a line dropout at full load. In this case, the circuit should not disable the downstream regulator if the input voltage falls after it is turned on; therefore, some form of hysteresis or latching is needed on the enable signal for the constant power load. The output capacitance of the VIA PFM should also be sized appropriately for a constant power load to prevent collapse of the output voltage of the module during line dropout (see Hold up Capacitance on Page 16). A constant-power load can be turned off after completion of the required hold up time during the power-down sequence or can be allowed to turn off when it reaches its own undervoltage shutdown point.

The timing diagram in Figure 23 shows the output voltage of the VIA PFM and the downstream regulator's enable pin voltage and output voltage of the PRM regulator for the power up and power down sequence. It is recommended to keep the time delay approximately 10 to 20 ms.

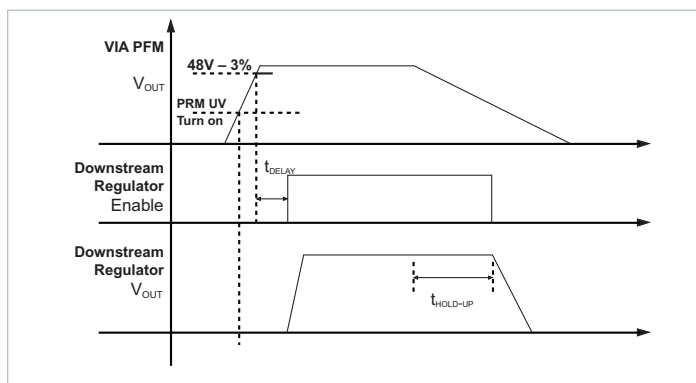

Figure 23 – PRM Enable Hold off Waveforms

Special care should be taken when enabling the constant-power load near the auto-ranger threshold, especially with an inductive source upstream of the VIA PFM. A load current spike may cause a large input voltage transient, resulting in a range change which could temporarily reduce the available power (see Adaptive Cell™ Topology below).

Adaptive Cell™ Topology

The Adaptive Cell topology utilizes magnetically coupled “top” and “bottom” primary cells that are adaptively configured in series or parallel by a configuration controller comprised of an array of switches. A microcontroller monitors operating conditions and defines the configuration of the top and bottom cells through a range control signal.

A comparator inside the microcontroller monitors the line voltage and compares it to an internal voltage reference.

If the input voltage of the PFM crosses above the positive going cell reconfiguration threshold voltage, the top cell and bottom cell configure in series and the unit operates in “high” range.

If the peak of input voltage of the unit falls below the negative-going range threshold voltage for two line cycles, the cell configuration controller configures the top cell and bottom cell in parallel, the unit operates in “low” range.

Power processing is held off while transitioning between ranges and the output voltage of the unit may temporarily droop. External output hold up capacitance should be sized to support power delivery to the load during cell reconfiguration. The minimum specified external output capacitance is sufficient to provide adequate ride-through during cell reconfiguration for typical applications. Waveforms showing active cell reconfiguration can be seen in Figure 9.

Dielectric Withstand

The chassis of the PFM is required to be connected to Protective Earth when installed in the end application and must satisfy the requirements of IEC 60950-1 for Class I products. Both sides of the housing are required to be connected to Protective Earth to satisfy safety and EMI requirements. Protective earthing can be accomplished through dedicated wiring harness (example: ring terminal clamped by mounting screw) or surface contact (example: pressure contact on bare conductive chassis or PCB copper layer with no solder mask).

The PFM contains an internal safety approved isolating component (VI ChiP) that provides the Reinforced Insulation from Input to Output. The isolating component is individually tested for Reinforced Insulation from Input to Output at 3000 Vac or 4242 Vdc prior to the final assembly of the VIA™.

When the VIA assembly is complete the Reinforced Insulation can only be tested at Basic Insulation values as specified in the electric strength Test Procedure noted in clause 5.2.2 of IEC 60950-1.

Test Procedure Note from IEC 60950-1

“For equipment incorporating both REINFORCED INSULATION and lower grades of insulation, care is taken that the voltage applied to the REINFORCED INSULATION does not overstress BASIC INSULATION or SUPPLEMENTARY INSULATION.”

Summary

The final VIA assembly contains basic insulation from input to case, reinforced insulation from input to output, and functional insulation from output to case.

The output of the VIA complies with the requirements of SELV circuits so only functional insulation is required from the output (SELV) to case (PE) because the case is required to be connected to protective earth in the final installation. The construction of the VIA can be summarized by describing it as a “Class II” component installed in a “Class I” subassembly. The reinforced insulation from input to output can only be tested at a basic insulation value of 2121 Vdc on the completely assembled VIA product.

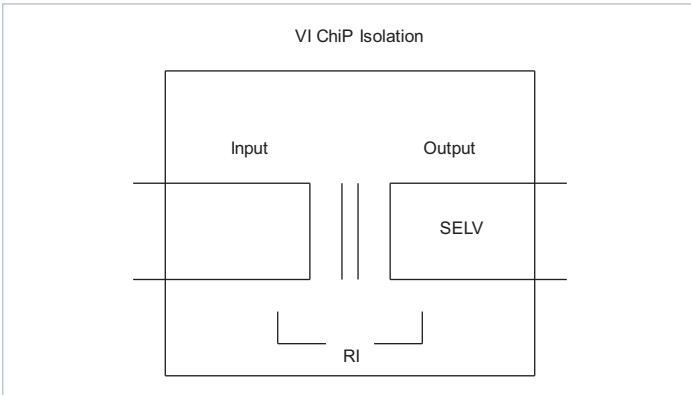

Figure 24 – VI Chip before final assembly in the VIA

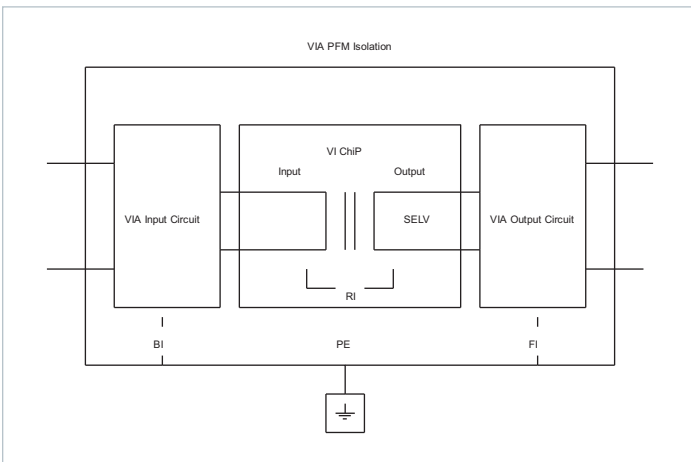
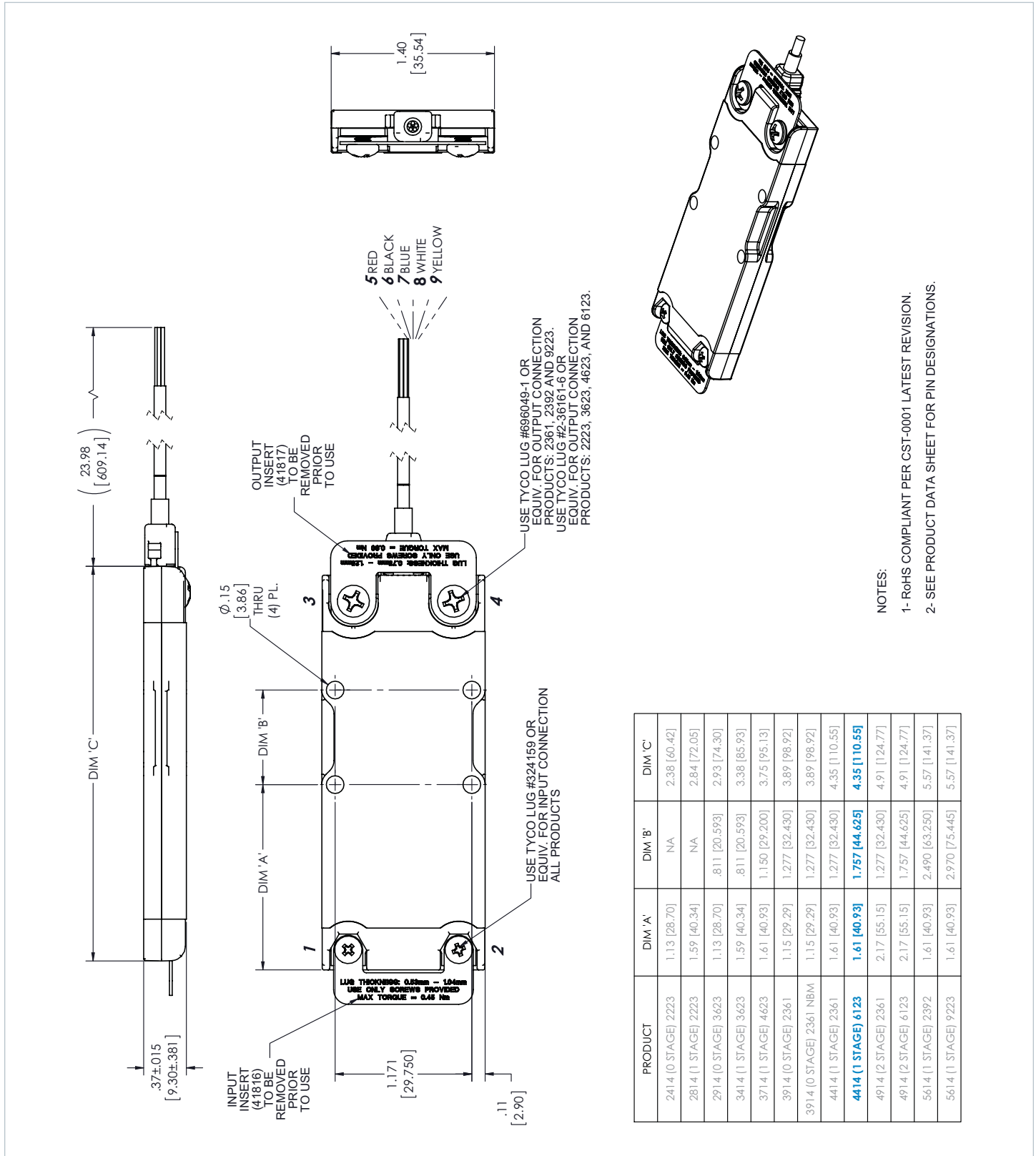

Figure 25 – PFM VIA after final assembly

VIA PFM Chassis Mount Package Mechanical Drawing



PRODUCT	DIM 'A'	DIM 'B'	DIM 'C'
2414 (0 STAGE) 2223	1.13 [28.70]	NA	2.38 [60.42]
2814 (1 STAGE) 2223	1.59 [40.34]	NA	2.84 [72.05]
2914 (0 STAGE) 3623	1.13 [28.70]	.81 [20.593]	2.93 [74.30]
3414 (1 STAGE) 3623	1.59 [40.34]	.81 [20.593]	3.38 [85.93]
3714 (1 STAGE) 4623	1.61 [40.93]	1.150 [29.200]	3.75 [95.13]
3914 (0 STAGE) 2361	1.15 [29.29]	1.277 [32.430]	3.89 [98.92]
3914 (0 STAGE) 2361 NBM	1.15 [29.29]	1.277 [32.430]	3.89 [98.92]
4414 (1 STAGE) 2361	1.61 [40.93]	1.277 [32.430]	4.35 [110.55]
4414 (1 STAGE) 6123	1.61 [40.93]	1.757 [44.625]	4.35 [110.55]
4914 (2 STAGE) 2361	2.17 [55.15]	1.277 [32.430]	4.91 [124.77]
4914 (2 STAGE) 6123	2.17 [55.15]	1.757 [44.625]	4.91 [124.77]
5614 (1 STAGE) 2392	1.61 [40.93]	2.490 [63.250]	5.57 [141.37]
5614 (1 STAGE) 9223	1.61 [40.93]	2.970 [75.445]	5.57 [141.37]

Product outline drawing; Product outline drawings are available in .pdf and .dxf formats. 3D mechanical models are available in .pdf and .step formats.

VIA PFM PCB Mount Package Mechanical Drawing and Recommended Land Pattern

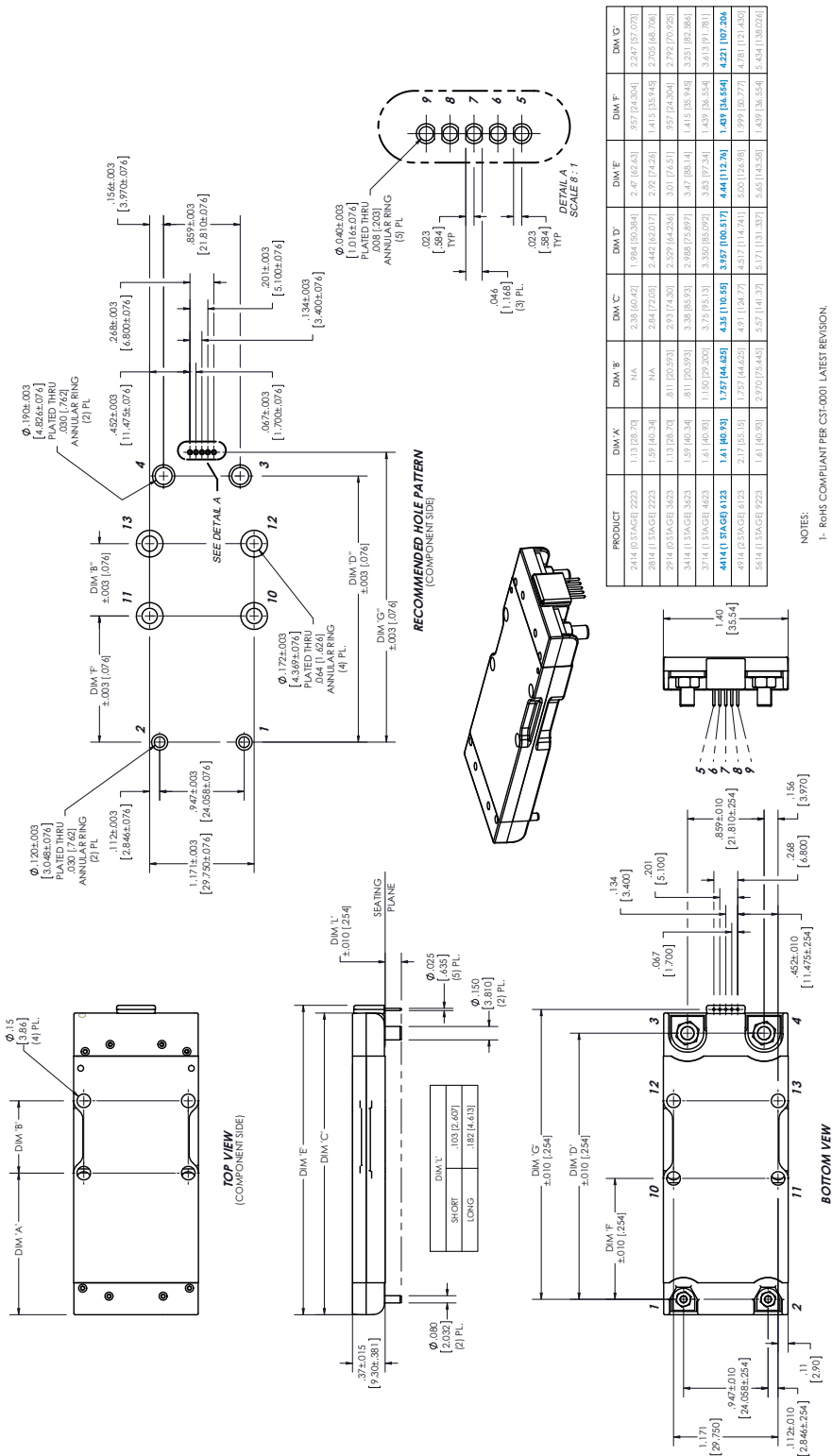

PRODUCT	DIM A'	DIM A	DIM B'	DIM B	DIM C'	DIM C	DIM D'	DIM D	DIM E'	DIM E	DIM F'	DIM F	DIM G'	DIM G
2414 (13ACGH) 2223	1.13 [28.70]	1.13 [28.70]	N/A	N/A	2.36 [60.42]	1.96 [50.38]	2.42 [62.63]	2.42 [62.63]	3.57 [92.50]	3.57 [92.50]	2.57 [65.25]	2.57 [65.25]	2.87 [73.02]	2.87 [73.02]
2814 (13ACGH) 2423	1.39 [35.34]	1.39 [35.34]	N/A	N/A	2.84 [72.65]	2.44 [62.01]	2.92 [74.26]	2.92 [74.26]	4.41 [112.48]	4.41 [112.48]	3.21 [81.91]	3.21 [81.91]	3.57 [92.50]	3.57 [92.50]
3414 (13ACGH) 3423	1.39 [35.34]	1.39 [35.34]	0.81 [20.57]	0.81 [20.57]	2.93 [74.50]	2.57 [65.25]	2.98 [75.87]	2.98 [75.87]	3.47 [88.14]	3.47 [88.14]	3.21 [81.91]	3.21 [81.91]	3.57 [92.50]	3.57 [92.50]
3714 (13ACGH) 4023	1.61 [40.90]	1.61 [40.90]	1.50 [38.10]	1.50 [38.10]	3.75 [95.31]	3.50 [89.02]	3.93 [100.02]	3.93 [100.02]	4.09 [104.04]	4.09 [104.04]	3.41 [87.10]	3.41 [87.10]	3.57 [92.50]	3.57 [92.50]
4414 (13ACGH) 1123	1.61 [40.90]	1.61 [40.90]	1.97 [50.03]	1.97 [50.03]	4.31 [110.65]	3.97 [100.81]	4.44 [112.76]	4.44 [112.76]	4.87 [124.21]	4.87 [124.21]	4.21 [107.26]	4.21 [107.26]	4.57 [116.20]	4.57 [116.20]
5814 (13ACGH) 9223	1.61 [40.90]	1.61 [40.90]	3.93 [99.44]	3.93 [99.44]	5.57 [141.37]	5.17 [131.30]	5.65 [143.58]	5.65 [143.58]	5.17 [131.30]	5.17 [131.30]	4.91 [124.27]	4.91 [124.27]	5.00 [127.03]	5.00 [127.03]

Revision History

Revision	Date	Description	Page Number(s)
1.0	12/24/15	Initial release	n/a

Vicor's comprehensive line of power solutions includes high density AC-DC and DC-DC modules and accessory components, fully configurable AC-DC and DC-DC power supplies, and complete custom power systems.

Information furnished by Vicor is believed to be accurate and reliable. However, no responsibility is assumed by Vicor for its use. Vicor makes no representations or warranties with respect to the accuracy or completeness of the contents of this publication. Vicor reserves the right to make changes to any products, specifications, and product descriptions at any time without notice. Information published by Vicor has been checked and is believed to be accurate at the time it was printed; however, Vicor assumes no responsibility for inaccuracies. Testing and other quality controls are used to the extent Vicor deems necessary to support Vicor's product warranty. Except where mandated by government requirements, testing of all parameters of each product is not necessarily performed.

Specifications are subject to change without notice.

Vicor's Standard Terms and Conditions

All sales are subject to Vicor's Standard Terms and Conditions of Sale, which are available on Vicor's webpage or upon request.

Product Warranty

In Vicor's standard terms and conditions of sale, Vicor warrants that its products are free from non-conformity to its Standard Specifications (the "Express Limited Warranty"). This warranty is extended only to the original Buyer for the period expiring two (2) years after the date of shipment and is not transferable.

UNLESS OTHERWISE EXPRESSLY STATED IN A WRITTEN SALES AGREEMENT SIGNED BY A DULY AUTHORIZED VICOR SIGNATORY, VICOR DISCLAIMS ALL REPRESENTATIONS, LIABILITIES, AND WARRANTIES OF ANY KIND (WHETHER ARISING BY IMPLICATION OR BY OPERATION OF LAW) WITH RESPECT TO THE PRODUCTS, INCLUDING, WITHOUT LIMITATION, ANY WARRANTIES OR REPRESENTATIONS AS TO MERCHANTABILITY, FITNESS FOR PARTICULAR PURPOSE, INFRINGEMENT OF ANY PATENT, COPYRIGHT, OR OTHER INTELLECTUAL PROPERTY RIGHT, OR ANY OTHER MATTER.

This warranty does not extend to products subjected to misuse, accident, or improper application, maintenance, or storage. Vicor shall not be liable for collateral or consequential damage. Vicor disclaims any and all liability arising out of the application or use of any product or circuit and assumes no liability for applications assistance or buyer product design. Buyers are responsible for their products and applications using Vicor products and components. Prior to using or distributing any products that include Vicor components, buyers should provide adequate design, testing and operating safeguards.

Vicor will repair or replace defective products in accordance with its own best judgment. For service under this warranty, the buyer must contact Vicor to obtain a Return Material Authorization (RMA) number and shipping instructions. Products returned without prior authorization will be returned to the buyer. The buyer will pay all charges incurred in returning the product to the factory. Vicor will pay all reshipment charges if the product was defective within the terms of this warranty.

Life Support Policy

VICOR'S PRODUCTS ARE NOT AUTHORIZED FOR USE AS CRITICAL COMPONENTS IN LIFE SUPPORT DEVICES OR SYSTEMS WITHOUT THE EXPRESS PRIOR WRITTEN APPROVAL OF THE CHIEF EXECUTIVE OFFICER AND GENERAL COUNSEL OF VICOR CORPORATION. As used herein, life support devices or systems are devices which (a) are intended for surgical implant into the body, or (b) support or sustain life and whose failure to perform when properly used in accordance with instructions for use provided in the labeling can be reasonably expected to result in a significant injury to the user. A critical component is any component in a life support device or system whose failure to perform can be reasonably expected to cause the failure of the life support device or system or to affect its safety or effectiveness. Per Vicor Terms and Conditions of Sale, the user of Vicor products and components in life support applications assumes all risks of such use and indemnifies Vicor against all liability and damages.

Intellectual Property Notice

Vicor and its subsidiaries own Intellectual Property (including issued U.S. and Foreign Patents and pending patent applications) relating to the products described in this data sheet. No license, whether express, implied, or arising by estoppel or otherwise, to any intellectual property rights is granted by this document. Interested parties should contact Vicor's Intellectual Property Department.

The products described on this data sheet are protected by the following U.S. Patents Numbers: Patents Pending.

Vicor Corporation

25 Frontage Road
Andover, MA, USA 01810
Tel: 800-735-6200
Fax: 978-475-6715

email

Customer Service: custserv@vicorpower.com
Technical Support: apps@vicorpower.com