

REVISIONS

REV.	DESCRIPTION	DATE	CMPLT. BY	APPRV.

GE TERMINAL BLOCK  
PIN NUMBERS

2	1
4	3
6	5
8	7
10	9
12	11
14	13
16	15
18	17
20	19
22	21
24	23
26	25
28	27
30	29
32	31
34	33
36	35
38	37
40	39

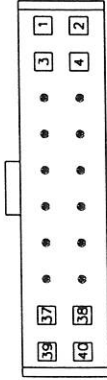

CRIMP AND POKE CONNECTOR  
PIN NUMBERS  
(WIRE INSERTION SIDE)

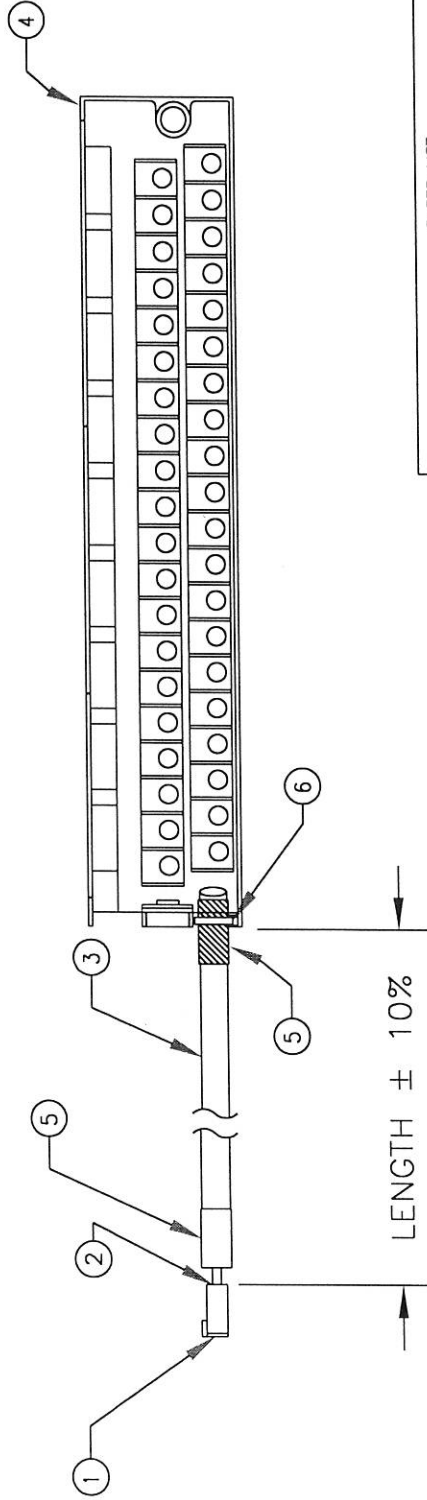

NOTES:

1. CUT CABLE AND STRIP CONDUCTORS AS REQUIRED TO ACHIEVE LENGTH SPECIFIED IN TABLE.
2. CUT UNUSED WIRE ENDS BACK TO THE JACKET BEFORE HEATING SHRINK TUBING.

PARTS LIST

BUB. #	DESCRIPTION	QTY.
1	CONNECTOR, 40-PIN, FEMALE	1
2	CRIMP AND POKE TERMINAL	40
3	CABLE, 40-COND. 22AWG	A/R
4	TERMINAL BLOCK, IC697ACC700	1
5	SHRINK TUBING	100mm
6	TIE WRAP, NYLON, 4"	6

CATALOG NO.	LENGTH (m)
998111	0.5
998112	1.0
998113	1.5
998114	2.0



WEIDMULLER INC.  
821 SOUTHLAKE BLVD.  
RICHMOND, VIRGINIA 23236

CAT. NO. VARIOUS

DRWN BY PSH  
APPROVED *EM*

REL. DATE  
10/15/97

DISTRIBUTION:  P/N  DWG.  PROD.  INSP.  OTHER

TOLERANCE ON :  
X.X = +/- 0.508 mm  
.XX = +/- 0.254 mm  
.XXX = +/- 0.127 mm  
X.XX = +/- .30  
UNLESS OTHERWISE SPECIFIED ALL DIMENSIONS ARE IN MILLIMETERS  
( ) INDICATES REFERENCE DIMENSIONS

PROPRIETARY RIGHTS :  
THIS DOCUMENT INCLUDES DESIGN AND ENGINEERING CONCEPTS WHICH INVOLVE PROPRIETARY AND CONFIDENTIAL INFORMATION OF WEIDMULLER INC. THIS DOCUMENT IS NOT TO BE REPRODUCED, COPIED, OR USED WITHOUT WRITTEN AUTHORITY FROM WEIDMULLER INC. IN RICHMOND, VIRGINIA.

CABLE ASSEMBLY  
GE FPA/C 9070-250

PRODUCTION RELEASE PAGE 1 SCALE: DO NOT SCALE

DRAWING NUMBER  
1100355

SIZE: A SHEET 1 OF 2

REV. 0